



NEWGARDEN



Flowerpots

DALIA	15
CAMELIA 40	17
CAMELIA 60	19
CAMELIA 80	21
CAMELIA LARGE	23
CAMELIA HIGH	25
AZALEA	27
HORTENSIA 30	29
HORTENSIA 40	29
HORTENSIA 40 HIGH	31
LIFT SUPPORT ACCESORIES	31
HORTENSIA 50	33
HORTENSIA 80	33
MARANTA 30X40	35
MARANTA 30X70	35
MARANTA 60X40	37
FICUS 60	39
FICUS 80	41
BAMBÚ 70	43
BAMBÚ 90	45
MAGNOLIA 30	47
MAGNOLIA 45	47
MAGNOLIA 60	49
MAGNOLIA 80	51
MAGNOLIA 120	53
MAGNOLIA 160	55
PALMA	57
MELISA 30	59
MELISA 40	61
MELISA 50	63
BROMELIA 28	65
BROMELIA 78	65
JUNCO	67
JARA	69
OLIVO 50	71
OLIVO HIGH	71
OLIVO LARGE	73
NARCISO 35	75
NARCISO 40	75
NARCISO 50	77
NARCISO 60	77
JAZMÍN	79
CLAVEL	79
CAMOMILA	81
PETUNIA	81
VIOLETA	83
GERBERA 33	85
GERBERA 45	85
GERBERA 50	85
GIRASOL	87
CALÉNDULA	87
ROSA	89
WALLY POTS	91
PLATES	93

Light and Deco

BULY COLLECTION	97
CUBY COLLECTION	101
LIGHTING COLLECTION	103
LIGHTING COLLECTION	105
LIGHTING COLLECTION	107



**Crafting
your
*indoor and
outdoor*
moments.**



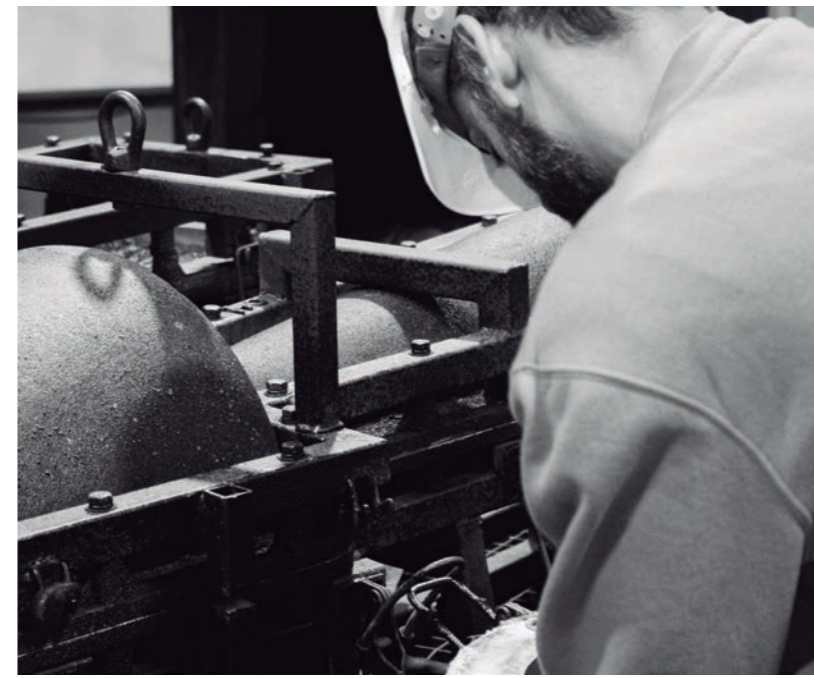
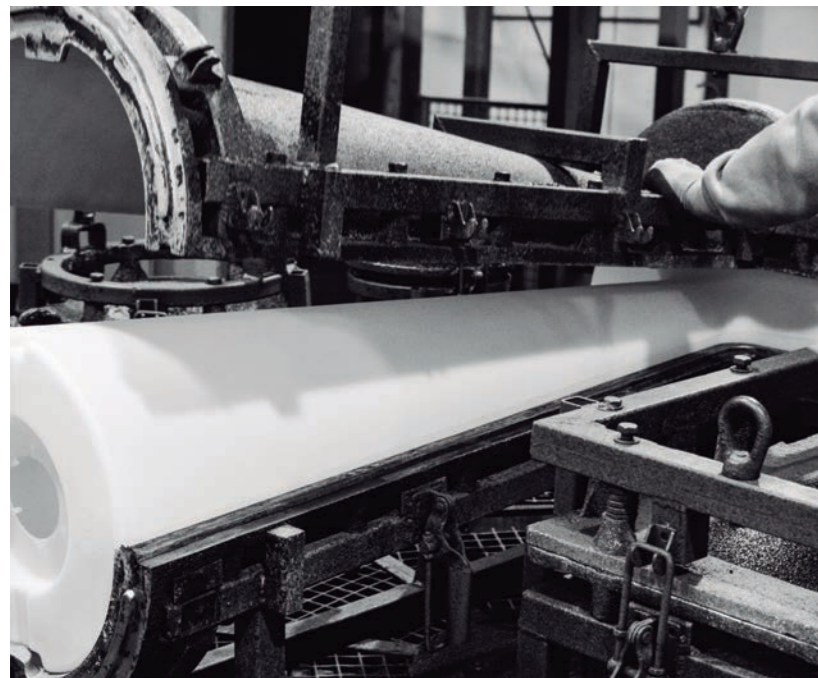
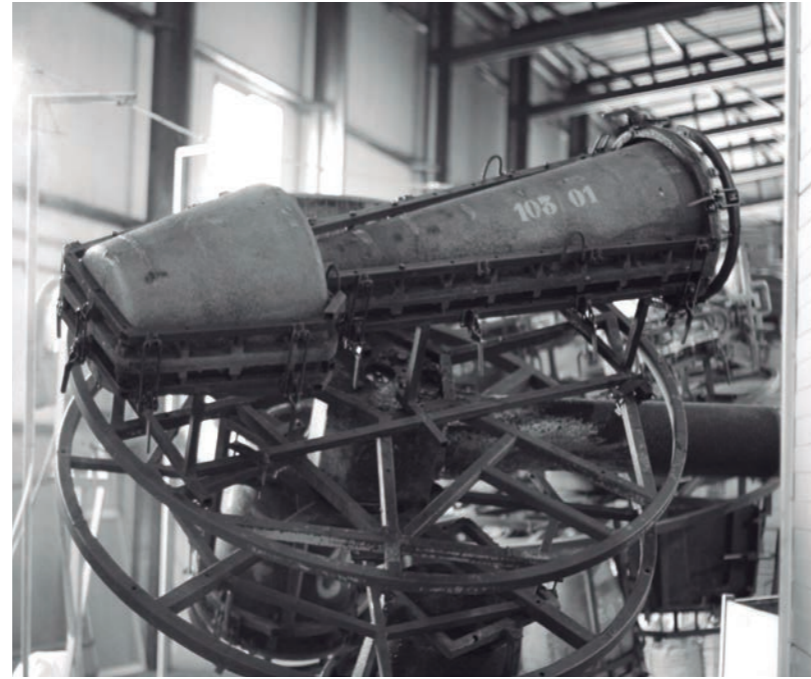

European
manufacturers
and designers
of moments.

Natural beauty



2

1

PRODUCTS
(1) CAMELIA 40

(2) CAMELIA 60

Dalia

DALIA 30

- 🌿 11,5 L
- 🌊 Includes water reservoir
- M** Polyethylene
- 📦 Packaging: Plastic bag
- 📦 Gross Weight (with packaging): 0,6kg

- White | ○ **REF: JDNDLA030BXNLNW**
- Black | ● **REF: JDNDLA030NXNLNW**
- Bronze | ● **REF: JDNDLA030ZXNLNW**
- Anthracite | ● **REF: JDNDLA030ANNLNW**

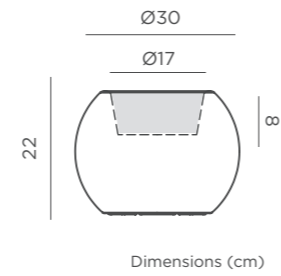

DALIA 50

- 🌿 56 L
- 🌊 Includes water reservoir
- M** Polyethylene
- 📦 Packaging: Plastic bag
- 📦 Gross Weight (with packaging): 1,7kg

- White | ○ **REF: JDNDLA050BXNLNW**
- Black | ● **REF: JDNDLA050NXNLNW**
- Bronze | ● **REF: JDNDLA050ZXNLNW**
- Anthracite | ● **REF: JDNDLA050ANNLNW**

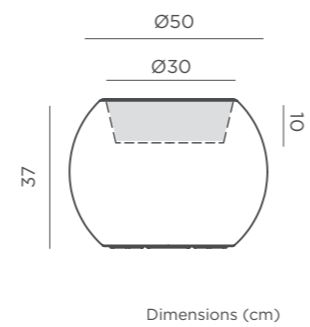

DALIA 70

- 🌿 142 L
- 🌊 Includes water reservoir
- M** Polyethylene
- 📦 Packaging: Plastic bag
- 📦 Gross Weight (with packaging): 3,1kg

- White | ○ **REF: JDNDLA070BXNLNW**
- Black | ● **REF: JDNDLA070NXNLNW**
- Bronze | ● **REF: JDNDLA070ZXNLNW**
- Anthracite | ● **REF: JDNDLA070ANNLNW**

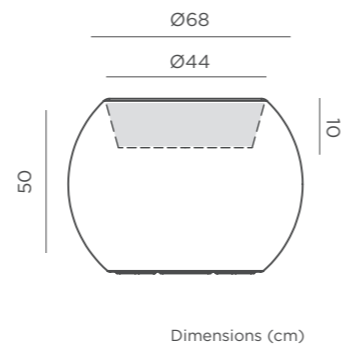

Camelia 40



CAMELIA 40 | WITH LIGHT

SOLAR & RECHARGEABLE BATTERY

REF: LUMCA040SSNW

- IP65 Outdoor & Indoor use
- Rechargeable Battery Electric Charge (driver not included)
- Warm Light (included)
- White Light (included)
- RGB Light (included)
- 600 lm
- Remote control (included)

- Dimmable
- Twilight sensor
- 5,5 L
- Integrated solar panel
- Polyethylene
- Packaging: 40,5 x 40,5 x 39,5 cm
- Gross Weight (with packaging): 3,5kg

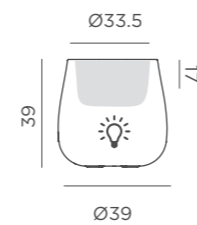

Dimensions (cm)

CABLE

REF: LUMCA040OFNW

- IP65 Outdoor & Indoor use
- White Light (included)
- 600 lm
- 5,5 L

- Polyethylene
- Packaging: 40,5 x 40,5 x 39,5 cm
- Gross Weight (with packaging): 3,2kg

CAMELIA 40 | WITHOUT LIGHT

OPAQUE COLOUR

- 32,45 L
- Polyethylene
- Packaging: Plastic bag
- Gross Weight (with packaging): 2,2kg

- White | REF: JDNCA040BXNW
- Black | REF: JDNCA040NXNW
- Bronze | REF: JDNCA040ZXNW
- Anthracite | REF: JDNCA040ANNW

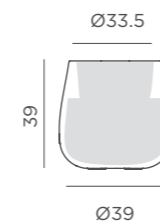

Dimensions (cm)

CAMELIA 40 | CIRCOOLAR

Recycled Multicolour | REF: JDNCLM040BXNLCR

- 32,45 L
- Recycled detergent bottles
- Packaging: Plastic bag
- Gross Weight (with packaging): 2,2kg

- Made of recycled detergent bottles

CAMELIA 40 | CIRCOOLAR

Recycled Blue | REF: JDNCLM040AZNLCR

- 32,45 L
- Recycled fishing nets
- Packaging: Plastic bag
- Gross Weight (with packaging): 2,2kg

- Made of recycled fishing nets



Camelia 60



CAMELIA 60 | WITH LIGHT

☀️ + 🔋 SOLAR & RECHARGEABLE BATTERY

REF: LUMCA060SSNW

- IP65 Outdoor & Indoor use
- ☀️ Solar + Rechargeable Battery (driver not included)
- 💡 Warm Light (included)
- 💡 White Light (included)
- 💡 RGB Light (included)
- lm 600 lm
- 🔋 Remote control (included)

- 📏 Dimmable
- 🌙 Twilight sensor
- 💧 29,4 L
- ☀️ Integrated solar panel
- M Polyethylene
- 📦 Packaging: 60,5 x 60,5 x 42,7 cm
- 📦 Gross Weight (with packaging): 5kg

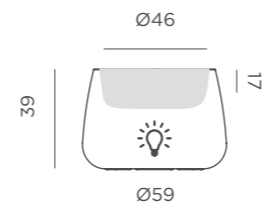

Dimensions (cm)

🔌 CABLE

REF: LUMCA060OFNW

- IP65 Outdoor & Indoor use
- 💡 White Light (included)
- lm 600 lm
- 💧 29,4 L

- M Polyethylene
- 📦 Packaging: 60 x 60 x 42 cm
- 📦 Gross Weight (with packaging): 5kg

CAMELIA 60 | WITHOUT LIGHT

OPAQUE COLOUR

- 💧 74 L
- M Polyethylene
- 📦 Packaging: Plastic bag
- 📦 Gross Weight (with packaging): 4,5kg

- White | ○ REF: JDNCA060BXNW
- Black | ● REF: JDNCA060NXNW
- Bronze | ● REF: JDNCA060ZXNW
- Anthracite | ● REF: JDNCA060ANNW

CAMELIA 60 | CIRCOOLAR

Recycled Multicolour |  REF: JDNCLM060BXNLCR



- 💧 74 L
- M Recycled detergent bottles
- 📦 Packaging: Plastic bag
- 📦 Gross Weight (with packaging): 4,5kg

  Made of recycled detergent bottles

CAMELIA 60 | CIRCOOLAR

Recycled Blue |  REF: JDNCLM060AZNLCR

- 💧 74 L
- M Recycled fishing nets
- 📦 Packaging: Plastic bag
- 📦 Gross Weight (with packaging): 4,5kg

  Made of recycled fishing nets

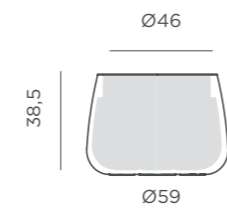

Dimensions (cm)



Camelia 80



CAMELIA 80 | WITH LIGHT

☀️ + 🔋 SOLAR & RECHARGEABLE BATTERY

REF: LUMCA080SSNW

- IP65 Outdoor & Indoor use
- ☀️ Solar + Rechargeable Battery (driver not included)
- 💡 Warm Light (included)
- 💡 White Light (included)
- 💡 RGB Light (included)
- lm 600 lm
- 📶 Remote control (included)

- 📶 Dimmable
- 🌙 Twilight sensor
- 💧 74,8 L
- ☀️ Integrated solar panel
- M Polyethylene
- 📦 Packaging: Plastic bag
- 📊 Gross Weight (with packaging): 10,5kg

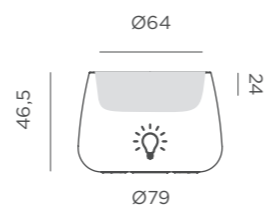

Dimensions (cm)

🔌 CABLE

REF: LUMCA080OFNW

- IP65 Outdoor & Indoor use
- 💡 White Light (included)
- lm 600 lm
- 💧 74,8 L

- M Polyethylene
- 📦 Packaging: Plastic bag
- 📊 Gross Weight (with packaging): 10,5kg

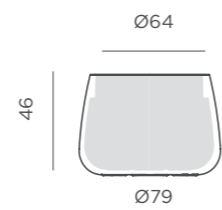

Dimensions (cm)

CAMELIA 80 | WITHOUT LIGHT

OPAQUE COLOUR

- 💧 178,4 L
- M Polyethylene
- 📦 Packaging: Plastic bag
- 📊 Gross Weight (with packaging): 10kg

- White | ○ REF: JDNCA080BXNW
- Black | ● REF: JDNCA080XNW
- Bronze | ● REF: JDNCA080ZXNW
- Anthracite | ● REF: JDNCA080ANNW

CAMELIA 80 | CIRCOOLAR

Recycled Multicolour |  REF: JDNCL080BXNLCR

- 💧 178,4 L
- M Recycled detergent bottles
- 📦 Packaging: Plastic bag
- 📊 Gross Weight (with packaging): 10kg

 Made of recycled detergent bottles

CAMELIA 80 | CIRCOOLAR

Recycled Blue |  REF: JDNCL080AZNLCR

- 💧 178,4 L
- M Recycled fishing nets
- 📦 Packaging: Plastic bag
- 📊 Gross Weight (with packaging): 10kg

 Made of recycled fishing nets



Camelia large



CAMELIA LARGE | WITH LIGHT

SOLAR & RECHARGEABLE BATTERY

REF: LUMCALARSSNW

- IP65 Outdoor & Indoor use
- Solar + Rechargeable Battery (driver not included)
- Warm Light (included)
- White Light (included)
- RGB Light (included)
- 600 lm
- Remote control (included)

- Dimmable
- Twilight sensor
- 43,4 L
- Integrated solar panel
- Polyethylene
- Packaging: 50 x 111 x 50 cm
- Gross Weight (with packaging): 7,5kg

CABLE

REF: LUMCALAROFNW

- IP65 Outdoor & Indoor use
- White Light (included)
- 600 lm
- 43,4 L

- Polyethylene
- Packaging: 50 x 111 X 50 cm
- Gross Weight (with packaging): 7,5kg

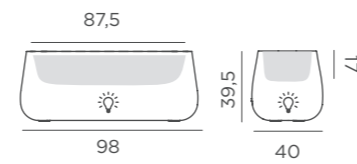

Dimensions (cm)

CAMELIA LARGE | WITHOUT LIGHT

OPAQUE COLOUR

- 101,6 L
- Polyethylene
- Packaging: Plastic bag
- Gross Weight (with packaging): 6kg

- White | REF: JDNCALARBXNW
- Black | REF: JDNCALARNXNW
- Bronze | REF: JDNCALARZXNW
- Anthracite | REF: JDNCALARANNW

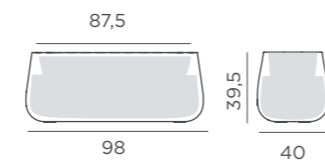

Dimensions (cm)

CAMELIA LARGE | CIRCOOLAR



Recycled Multicolour | REF: JDNCLG100BXNLCR

- 101,6 L
- Recycled detergent bottles
- Packaging: Plastic bag
- Gross Weight (with packaging): 6kg

- Made of recycled detergent bottles

CAMELIA LARGE | CIRCOOLAR



Recycled Blue | REF: JDNCLG100AZNLCR

- 101,6 L
- Recycled fishing nets
- Packaging: Plastic bag
- Gross Weight (with packaging): 6kg

- Made of recycled fishing nets



Camelia high



CAMELIA HIGH | WITH LIGHT

☀️ + 🔋 SOLAR & RECHARGEABLE BATTERY

REF: LUMCAHIGSSNW

- IP65 Outdoor & Indoor use
- ☀️ Solar + Rechargeable Battery (driver not included)
- 💡 Warm Light (included)
- 💡 White Light (included)
- 💡 RGB Light (included)
- lm 600 lm
- 📶 Remote control (included)

- 📶 Dimmable
- 🌙 Twilight sensor
- 💧 14 L
- ☀️ Integrated solar panel
- M Polyethylene
- 📦 Packaging: 40,5 x 40,5 x 69,5 cm
- 📦 Gross Weight (with packaging): 4kg

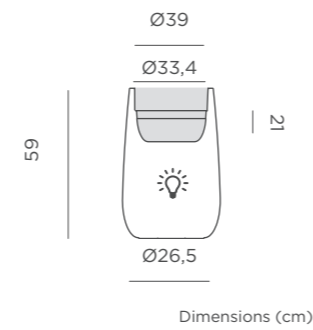

🔌 CABLE

REF: LUMCAHIGOFNW

- IP65 Outdoor & Indoor use
- 💡 White Light (included)
- lm 600 lm
- 💧 14 L

- M Polyethylene
- 📦 Packaging: Plastic bag
- 📦 Gross Weight (with packaging): 4kg

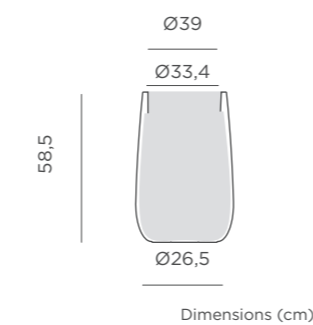

CAMELIA HIGH | WITHOUT LIGHT

OPAQUE COLOUR

- 💧 53,7 L
- M Polyethylene
- 📦 Packaging: Plastic bag
- 📦 Gross Weight (with packaging): 3,5kg

- White | ○ REF: JDNCAHIGBXNW
- Black | ● REF: JDNCAHIGNXNW
- Bronze | ● REF: JDNCAHIGZXNW
- Anthracite | ● REF: JDNCAHIGANNW

CAMELIA HIGH | CIRCOOLAR



Recycled Multicolour | REF: LUMCMH040BXNLCR

- 💧 53,7 L
- M Recycled detergent bottles
- 📦 Packaging: Plastic bag
- 📦 Gross Weight (with packaging): 3,5kg

- ♻️ Made of recycled detergent bottles

CAMELIA HIGH | CIRCOOLAR



Recycled Blue | REF: LUMCMH040AZNLCR

- 💧 53,7 L
- M Recycled fishing nets
- 📦 Packaging: Plastic bag
- 📦 Gross Weight (with packaging): 3,5kg

- ♻️ Made of recycled fishing nets



Azalea

AZALEA 30

- 🍷 9,4 L
- 🌿 Includes water reservoir
- M** Polyethylene
- 📦 Packaging: Plastic bag
- 📦 Gross Weight (with packaging): 1kg

- White | ○ **REF: JDNAZA030BXNLNW**
- Black | ● **REF: JDNAZA030NXNLNW**
- Bronze | ● **REF: JDNAZA030ZXNLNW**
- Terracota | ● **REF: JDNAZA030TXNLNW**
- Anthracite | ● **REF: JDNAZA030ANLNLW**

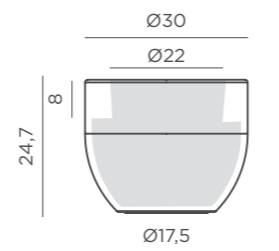

Dimensions (cm)

AZALEA 40

- 🍷 19,7 L
- 🌿 Includes water reservoir
- M** Polyethylene
- 📦 Packaging: Plastic bag
- 📦 Gross Weight (with packaging): 2kg

- White | ○ **REF: JDNAZA040BXNLNW**
- Black | ● **REF: JDNAZA040NXNLNW**
- Bronze | ● **REF: JDNAZA040ZXNLNW**
- Terracota | ● **REF: JDNAZA040TXNLNW**
- Anthracite | ● **REF: JDNAZA040ANLNLW**

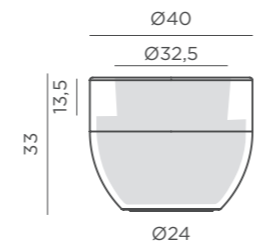

Dimensions (cm)

AZALEA 50

- 🍷 37,8 L
- 🌿 Includes water reservoir
- M** Polyethylene
- 📦 Packaging: Plastic bag
- 📦 Gross Weight (with packaging): 3,5kg

- White | ○ **REF: JDNAZA050BXNLNW**
- Black | ● **REF: JDNAZA050NXNLNW**
- Bronze | ● **REF: JDNAZA050ZXNLNW**
- Terracota | ● **REF: JDNAZA050TXNLNW**
- Anthracite | ● **REF: JDNAZA050ANLNLW**

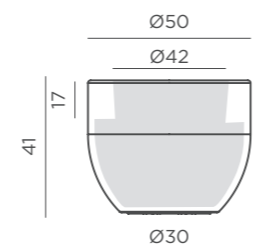

Dimensions (cm)



Hortensia 30

HORTENSIA 30

- 17,8 L
- Includes water reservoir
- M Polyethylene
- Packaging: Plastic bag
- Gross Weight (with packaging): 1kg

- White | REF: JDNHOR030BXNW
- Black | REF: JDNHOR030NXNW
- Bronze | REF: JDNHOR030ZXNW
- Taupe | REF: JDNHOR030KXNW
- Terracota | REF: JDNHOR030TXNW
- Anthracite | REF: JDNHOR030ANNW

HORTENSIA 30 | CIRCOOLAR

Recycled Multicolour |  REF: JDNHOR030BXNLCR



- 17,8 L
- M Recycled detergent cans
- Packaging: Plastic bag
- Gross Weight (with packaging): 1kg

  Made of recycled detergent bottles

HORTENSIA 30 | CIRCOOLAR

Recycled Blue |  REF: JDNHOR030AZNLCR

- 17,8 L
- M Recycled fishing nets
- Packaging: Plastic bag
- Gross Weight (with packaging): 1kg

  Made of recycled fishing nets

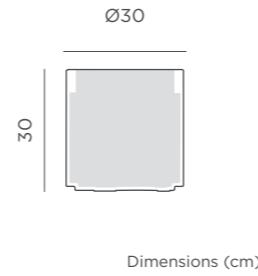

Hortensia 40

HORTENSIA 40

- 40 L
- Includes water reservoir
- M Polyethylene
- Packaging: Plastic bag
- Gross Weight (with packaging): 2,5kg

- White | REF: JDNHOR040BXNW
- Black | REF: JDNHOR040NXNW
- Bronze | REF: JDNHOR040ZXNW
- Taupe | REF: JDNHOR040KXNW
- Terracota | REF: JDNHOR040TXNW
- Anthracite | REF: JDNHOR040ANNW

HORTENSIA 40 | CIRCOOLAR

Recycled Multicolour |  REF: JDNHOR040BXNLCR

- 40 L
- M Recycled detergent cans
- Packaging: Plastic bag
- Gross Weight (with packaging): 2,5kg

  Made of recycled detergent bottles

HORTENSIA 40 | CIRCOOLAR

Recycled Blue |  REF: JDNHOR040AZNLCR

- 40 L
- M Recycled fishing nets
- Packaging: Plastic bag
- Gross Weight (with packaging): 2,5kg

  Made of recycled fishing nets

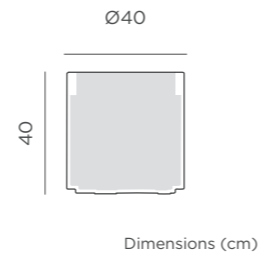

Hortensia 40 high

HORTENSIA 40 HIGH

- 83,4 L
- Includes water reservoir
- Polyethylene
- Packaging: Plastic bag
- Gross Weight (with packaging): 4kg

- White | ○ REF: JDNHOH040BXNLNW
- Black | ● REF: JDNHOH040NXNLNW
- Bronze | ● REF: JDNHOH040ZXNLNW
- Taupe | ● REF: JDNHOH040KXNLNW
- Terracota | ● REF: JDNHOH040TXNLNW
- Anthracite | ● REF: JDNHOH040ANLNLNW

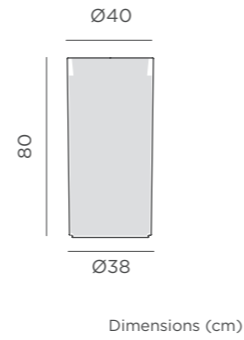

HORTENSIA 40 HIGH | CIRCOOLAR

Recycled Multicolour | REF: JDNHOH040BXNLCR

- 83,4 L
- Recycled detergent cans
- Packaging: Plastic bag
- Gross Weight (with packaging): 4kg

Made of recycled detergent bottles

HORTENSIA 40 HIGH | CIRCOOLAR

Recycled Blue | REF: JDNHOH040AZNLCR

- 83,4 L
- Recycled fishing nets
- Packaging: Plastic bag
- Gross Weight (with packaging): 4kg

Made of recycled fishing nets



Flowerpots | Hortensia | Lift support accessory

Lift support accessories

LIFT SUPPORT ACCESSORIES | ONLY FOR HORTENSIA 30

SUPPORT ACCESSORY 40cm

- Lacquered Iron
- Packaging: 29,2 x 36,9 x 2 cm
- Gross Weight (with packaging): 0,67kg

- Black | ● REF: JDNLIFT30041NXNW
- Brass | ● REF: JDNLIFT30041BRNW

SUPPORT ACCESSORY 100cm

- Lacquered Iron
- Packaging: 29,5 x 97 x 2,5 cm
- Gross Weight (with packaging): 1,62kg

- Black | ● REF: JDNLIFT30110NXNW
- Brass | ● REF: JDNLIFT30110BRNW

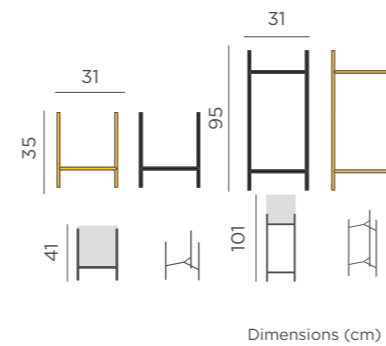

Hortensia 50

HORTENSIA 50

- 81 L
- Includes water reservoir
- M Polyethylene
- Packaging: Plastic bag
- Gross Weight (with packaging): 4kg

- White | ○ REF: JDNHOR050BXNW
- Black | ● REF: JDNHOR050NXNW
- Bronze | ● REF: JDNHOR050ZXNW
- Taupe | ● REF: JDNHOR050KXNW
- Terracota | ● REF: JDNHOR050TXNW
- Anthracite | ● REF: JDNHOR050ANNW

HORTENSIA 50 | CIRCOOLAR

Recycled Multicolour | REF: JDNHOR050BXNLCR

- 81 L
- M Recycled detergent cans
- Packaging: Plastic bag
- Gross Weight (with packaging): 4kg

Made of recycled detergent bottles

HORTENSIA 50 | CIRCOOLAR

Recycled Blue | REF: JDNHOR050AZNLCR

- 81 L
- M Recycled fishing nets
- Packaging: Plastic bag
- Gross Weight (with packaging): 4kg

Made of recycled fishing nets

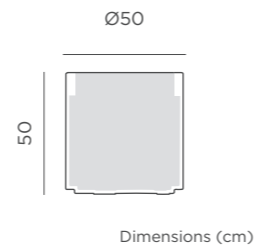

Hortensia 80

HORTENSIA 80 BIG SIZE XXL

- 343 L
- Includes water reservoir
- M Polyethylene
- Packaging: Plastic bag
- Gross Weight (with packaging): 12kg

- White | ○ REF: JDNHOR080BXNW
- Black | ● REF: JDNHOR080NXNW
- Bronze | ● REF: JDNHOR080ZXNW
- Terracota | ● REF: JDNHOR080TXNW
- Anthracite | ● REF: JDNHOR080ANNW

HORTENSIA 80 | CIRCOOLAR

Recycled Multicolour | REF: JDNHOR080BXNLCR

- 343 L
- M Recycled detergent cans
- Packaging: Plastic bag
- Gross Weight (with packaging): 12kg

Made of recycled detergent bottles

HORTENSIA 80 | CIRCOOLAR

Recycled Blue | REF: JDNHOR080AZNLCR

- 343 L
- M Recycled fishing nets
- Packaging: Plastic bag
- Gross Weight (with packaging): 12kg

Made of recycled fishing nets

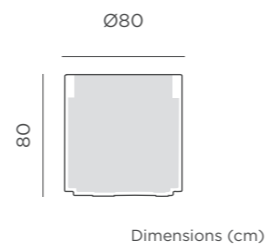



Maranta 30x40

MARANTA 30 X 40

OPAQUE COLOUR

- 🍷 6.3 L
- M** Polyethylene
- 📦 Packaging: Plastic bag
- 📦 Gross Weight (with packaging): 1.2kg

- White | ○ REF: JDNMRT030BXNLNW
- Bronze | ● REF: JDNMRT030ZXNLNW
- Anthracite | ● REF: JDNMRT030ANNLNW

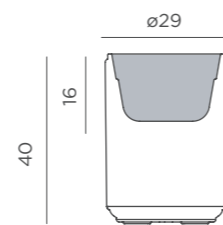

Dimensions (cm)

Maranta 30x70

MARANTA 30 X 70

OPAQUE COLOUR

- 🍷 8.5 L
- M** Polyethylene
- 📦 Packaging: Plastic bag
- 📦 Gross Weight (with packaging): 1.9kg

- White | ○ REF: JDNMRT070BXNLNW
- Bronze | ● REF: JDNMRT070ZXNLNW
- Anthracite | ● REF: JDNMRT070ANNLNW

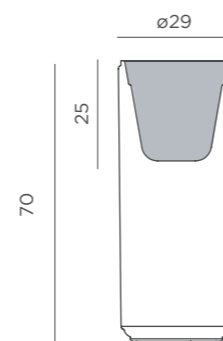

Dimensions (cm)



Maranta 60x40

MARANTA 60 X 40

OPAQUE COLOUR

- 34,4 L
- M Polyethylene
- 📦 Packaging: Plastic bag
- 📦 Gross Weight (with packaging): 3kg

- White | ○ REF: JDNMRT060BXNLNW
- Bronze | ● REF: JDNMRT060ZXNLNW
- Anthracite | ● REF: JDNMRT060ANLNLNW

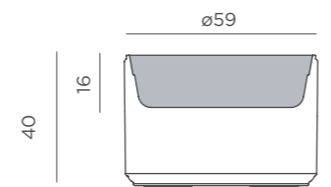

Ficus 60



FICUS 60 | WITH LIGHT

☀️ + 🔋 SOLAR & RECHARGEABLE BATTERY

REF: LUMFC060SSNW

- IP65 Outdoor & Indoor use
- ☀️ Solar + Rechargeable Battery (driver not included)
- 💡 Warm Light (included)
- 💡 White Light (included)
- 💡 RGB Light (included)
- lm 600 lm
- 📶 Remote control (included)

- 🔊 Dimmable
- 🌙 Twilight sensor
- 🍷 9 L
- ☀️ Integrated solar panel
- M Polyethylene
- 📦 Packaging: 29,4 x 29,4 x 59,5 cm
- 📦 Gross Weight (with packaging): 2,98kg

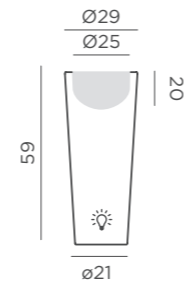

Dimensions (cm)

🔌 CABLE

REF: LUMFC060OFNW

- IP65 Outdoor & Indoor use
- 💡 White Light (included)
- lm 600 lm
- 🍷 9 L

- M Polyethylene
- 📦 Packaging: 29,4 x 29,4 x 59,5 cm
- 📦 Gross Weight (with packaging): 2,6kg

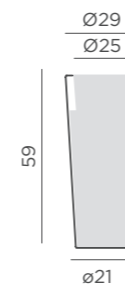

Dimensions (cm)

FICUS 60 | WITHOUT LIGHT

OPAQUE COLOUR

- 🍷 16,1 L
- M Polyethylene
- 📦 Packaging: Plastic bag
- 📦 Gross Weight (with packaging): 2,1kg

- White | ○ REF: JDNFC060BXNW
- Black | ● REF: JDNFC060NXNW
- Bronze | ● REF: JDNFC060ZXNW
- Anthracite | ● REF: JDNFC060ANNW



Ficus 80



FICUS 80 | WITH LIGHT

☀️ + 🔋 SOLAR & RECHARGEABLE BATTERY

REF: LUMFC080SSNW

- IP65 Outdoor & Indoor use
- ☀️ Solar + Rechargeable Battery (driver not included)
- 💡 Warm Light (included)
- 💡 White Light (included)
- 💡 RGB Light (included)
- lm 600 lm
- 📶 Remote control (included)

- 📶 Dimmable
- 🌙 Twilight sensor
- 💧 9,5 L
- ☀️ Integrated solar panel
- M Polyethylene
- 📦 Packaging: 29,5 x 29,5 x 80 cm
- 📦 Gross Weight (with packaging): 3,2kg

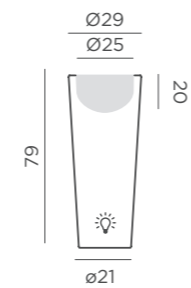

Dimensions (cm)

🔌 CABLE

REF: LUMFC080OFNW

- IP65 Outdoor & Indoor use
- 💡 White Light (included)
- lm 600 lm
- 💧 9,5 L

- M Polyethylene
- 📦 Packaging: 29,5 x 29,5 x 80 cm
- 📦 Gross Weight (with packaging): 3,2kg

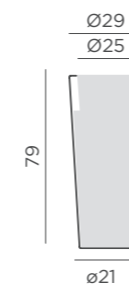

Dimensions (cm)

FICUS 80 | WITHOUT LIGHT

OPAQUE COLOUR

- 💧 22,5 L
- M Polyethylene
- 📦 Packaging: Plastic bag
- 📦 Gross Weight (with packaging): 2,7kg

- White | ○ REF: JDNFC080BXNW
- Black | ● REF: JDNFC080NXNW
- Bronze | ● REF: JDNFC080ZXNW
- Anthracite | ● REF: JDNFC080ANNW



Bambú 70

BAMBU 70 | WITH LIGHT

RECHARGEABLE BATTERY

REF: LUMBM070WLNW

- IP65 Outdoor & Indoor use
- Rechargeable Battery Electric Charge (driver not included)
- White Light (included)
- RGB Light (included)
- 315 lm
- Remote control (included)
- Dimmable

- Led tube lighting (included)
- 15,8 L
- Integrated solar panel
- M Polyethylene
- Packaging: 40 x 40 x 70 cm
- Gross Weight (with packaging): 4,5kg

CABLE

REF: LUMBM070OFNW

- IP65 Outdoor & Indoor use
- White Light (included)
- 600 lm
- 15,8L

- M Polyethylene
- Packaging: 40 x 40 x 70 cm
- Gross Weight (with packaging): 4,5kg

BAMBU 70 | WITHOUT LIGHT

OPAQUE COLOUR

- 15,8 L
- M Polyethylene
- Packaging: 40 x 40 x 70
- Gross Weight (with packaging): 4kg

- White | ○ REF: JDNBM070BXNW
- Black | ● REF: JDNBM070NXNW
- Bronze | ● REF: JDNBM070ZXNW
- Terracota | ● REF: JDNBM070TXNW
- Anthracite | ● REF: JDNBM070ANNW

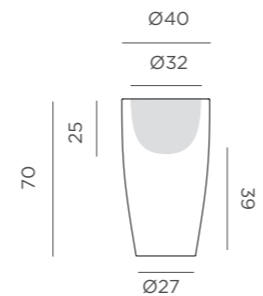

Dimensions (cm)





Bambú 90

BAMBU 90 | WITH LIGHT

RECHARGEABLE BATTERY

REF: LUMB090TWLNW

IP65 Outdoor & Indoor use

Rechargeable Battery Electric Charge (driver not included)

White Light (included)

RGB Light (included)

335 lm

Remote control (included)

Dimmable

Led tube lighting (included)

15,8 L

Integrated solar panel

Polyethylene

Packaging: 40 x 40 x 90 cm

Gross Weight (with packaging): 6,5kg

CABLE

REF: LUMB090OFNW

IP65 Outdoor & Indoor use

White Light (included)

900 lm

Led tube lighting (included)

15,8L

Polyethylene

Packaging: 40 x 40 x 90 cm

Gross Weight (with packaging): 6,5kg

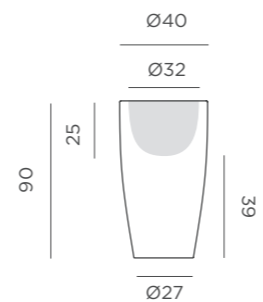

Dimensions (cm)

BAMBU 90 | WITHOUT LIGHT

OPAQUE COLOUR

15,8 L

Polyethylene

Packaging: 40 x 40 x 90 cm

Gross Weight (with packaging): 6kg

White | ○ REF: JDNBM090BXNW

Black | ● REF: JDNBM090NXNW

Bronze | ● REF: JDNBM090ZXNW

Terracota | ● REF: JDNBM090TXNW

Anthracite | ● REF: JDNBM090ANNW



Magnolia 30

MAGNOLIA 30 | WITH LIGHT

SOLAR & RECHARGEABLE BATTERY

REF: LUMMG030SSNW

- IP65** Outdoor & Indoor use
- Solar + Rechargeable Battery (driver not included)
- Warm Light (included)
- White Light (included)
- RGB Light (included)
- lm** 600 lm
- Remote control (included)

- Dimmable
- Twilight sensor
- 3,7 L
- Integrated solar panel
- M** Polyethylene
- Packaging: 32,5 x 32,5 x 33 cm
- Gross Weight (with packaging): 1,7kg

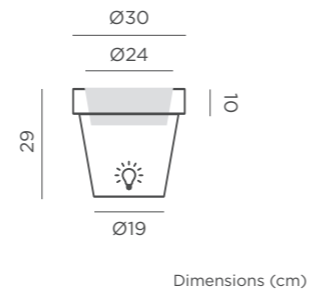

MAGNOLIA 30 | WITHOUT LIGHT

OPAQUE COLOUR

- 7,9 L
- M** Polyethylene
- Packaging: Plastic bag
- Gross Weight (with packaging): 0,9kg

- White | **REF: JDNMG030BXNW**
- Black | **REF: JDNMG030NXNW**
- Bronze | **REF: JDNMG030ZXNW**
- Anthracite | **REF: JDNMG030ANNW**

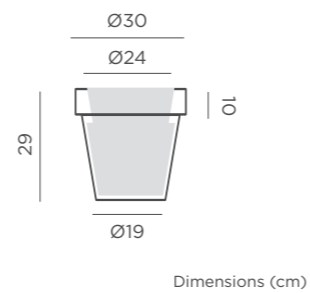

Magnolia 45

MAGNOLIA 45 | WITH LIGHT

SOLAR & RECHARGEABLE BATTERY

REF: LUMMG045SSNW

- IP65** Outdoor & Indoor use
- Solar + Rechargeable Battery (driver not included)
- Warm Light (included)
- White Light (included)
- RGB Light (included)
- lm** 600 lm
- Remote control (included)

- Dimmable
- Twilight sensor
- 19,4 L
- Integrated solar panel
- M** Polyethylene
- Packaging: 46 x 46 x 46,5 cm
- Gross Weight (with packaging): 4,75kg

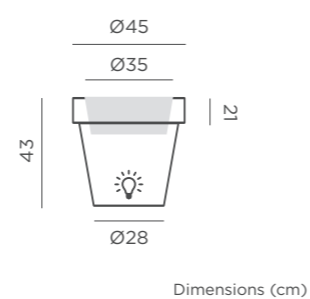

CABLE

REF: LUMMG045OFNW

- IP65** Outdoor & Indoor use
- White Light (included)
- lm** 600 lm
- 19,4 L

- M** Polyethylene
- Packaging: 46 x 46 x 46,5 cm
- Gross Weight (with packaging): 4kg

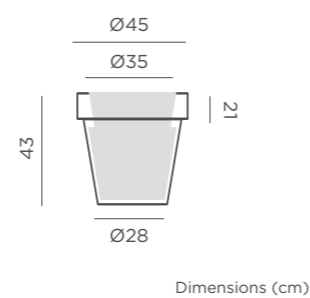

MAGNOLIA 45 | WITHOUT LIGHT

OPAQUE COLOUR

- 33,4 L
- M** Polyethylene
- Packaging: Plastic bag
- Gross Weight (with packaging): 2kg

- White | **REF: JDNMG045BXNW**
- Black | **REF: JDNMG045NXNW**
- Bronze | **REF: JDNMG045ZXNW**
- Anthracite | **REF: JDNMG045ANNW**





Magnolia 60

MAGNOLIA 60 | WITH LIGHT

☀️ + 🔋 SOLAR & RECHARGEABLE BATTERY

REF: LUMMG060SSNW

- IP65 Outdoor & Indoor use
- ☀️ Solar + Rechargeable Battery (driver not included)
- 💡 Warm Light (included)
- 💡 White Light (included)
- 💡 RGB Light (included)
- lm 600 lm
- 📶 Remote control (included)

- 📶 Dimmable
- 🌙 Twilight sensor
- 💧 36,7 L
- ☀️ Integrated solar panel
- M Polyethylene
- 📦 Packaging: 59 x 59 x 59 cm
- 📦 Gross Weight (with packaging): 7kg

🔌 CABLE

REF: LUMMG060OFNW

- IP65 Outdoor & Indoor use
- 💡 White Light (included)
- lm 600 lm
- 💧 36,7 L

- M Polyethylene
- 📦 Packaging: 59 x 59 x 59 cm
- 📦 Gross Weight (with packaging): 7kg

MAGNOLIA 60 | WITHOUT LIGHT

OPAQUE COLOUR

- 💧 82,3 L
- M Polyethylene
- 📦 Packaging: Plastic bag
- 📦 Gross Weight (with packaging): 5kg

- White | ○ REF: JDNMG060BXNW
- Black | ● REF: JDNMG060NXNW
- Bronze | ● REF: JDNMG060ZXNW
- Anthracite | ● REF: JDNMG060ANNW

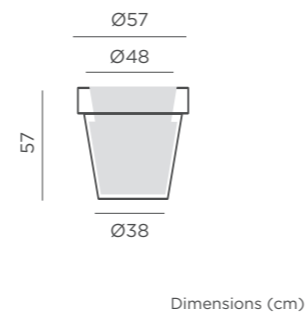
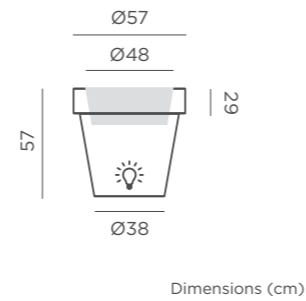

















Magnolia 80

MAGNOLIA 80 | WITH LIGHT BIG SIZE

SOLAR & RECHARGEABLE BATTERY

REF: JDNMGN080XXSSNW

-  Outdoor & Indoor use
-  Solar + Rechargeable Battery (driver not included)
-  Warm Light (included)
-  White Light (included)
-  RGB Light (included)
-  600 lm
-  Remote control (included)

-  Dimmable
-  Twilight sensor
-  82,5 L
-  Integrated solar panel
-  Polyethylene
-  Packaging: Plastic bag
-  Gross Weight (with packaging): 16kg

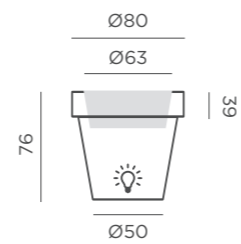



Dimensions (cm)

CABLE

REF: JDNMGN080XXOFNW

-  Outdoor & Indoor use
-  White Light (included)
-  600 lm
-  82,5 L

-  Polyethylene
-  Packaging: Plastic bag
-  Gross Weight (with packaging): 16kg

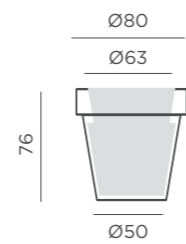





BIG SIZE

Dimensions (cm)

MAGNOLIA 80 | WITHOUT LIGHT BIG SIZE

OPAQUE COLOUR

-  207 L
-  Includes water reservoir
-  Polyethylene
-  Packaging: Plastic bag
-  Gross Weight (with packaging): 5kg

- White |  REF: JDNMGN080BXNLNW
- Black |  REF: JDNMGN080NXNLNW
- Bronze |  REF: JDNMGN080ZXNLNW
- Anthracyte |  REF: JDNMGN080ANLNLNW





Magnolia 120

MAGNOLIA 120 | WITH LIGHT BIG SIZE XXL

SOLAR & RECHARGEABLE BATTERY

REF: JDNMGN120XXSSNW

- Outdoor & Indoor use
- Solar + Rechargeable Battery (driver not included)
- Warm Light (included)
- White Light (included)
- RGB Light (included)
- 600 lm
- Remote control (included)

- Dimmable
- Twilight sensor
- 282.2 L
- Integrated solar panel
- Polyethylene
- Packaging: Plastic bag
- Gross Weight (with packaging): 36kg

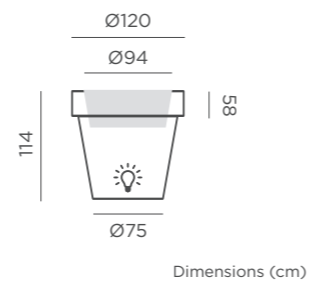

CABLE

REF: JDNMGN120XXOFNW

- Outdoor & Indoor use
- White Light (included)
- 600 lm
- 282.2 L

- Polyethylene
- Packaging: Plastic bag
- Gross Weight (with packaging): 36kg

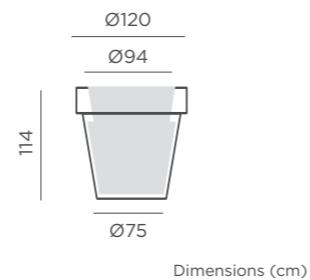

MAGNOLIA 120 | WITHOUT LIGHT BIG SIZE XXL

OPAQUE COLOUR

- 752.6 L
- Polyethylene
- Packaging: Plastic bag
- Gross Weight (with packaging): 35kg

- White | REF: JDNMGN120BXNLNW
- Black | REF: JDNMGN120NXNLNW
- Bronze | REF: JDNMGN120ZXNLNW
- Anthracite | REF: JDNMGN120ANLNLNW





Magnolia 160

MAGNOLIA 160 | WITH LIGHT BIG SIZE XXL

SOLAR & RECHARGEABLE BATTERY

- IP65 Outdoor & Indoor use
- Solar + Rechargeable Battery (driver not included)
- Warm Light (included)
- White Light (included)
- RGB Light (included)
- 600 lm
- Remote control (included)

REF: JDNMGN160XXSSNW

- Dimmable
- Twilight sensor
- 644 L
- Integrated solar panel
- Polyethylene
- Packaging: Plastic bag
- Gross Weight (with packaging): 64kg

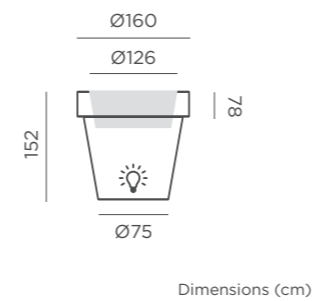

CABLE

REF: JDNMGN160XXOFNW

- IP65 Outdoor & Indoor use
- White Light (included)
- 600 lm
- 644 L

- Polyethylene
- Packaging: Plastic bag
- Gross Weight (with packaging): 64kg

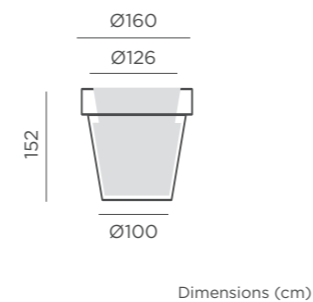

MAGNOLIA 160 | WITHOUT LIGHT BIG SIZE XXL

OPAQUE COLOUR

- 2000 L
- Polyethylene
- Packaging: Plastic bag
- Gross Weight (with packaging): 64kg

- White | REF: JDNMGN120BXNW
- Black | REF: JDNMGN120NXNW
- Bronze | REF: JDNMGN120ZXNW
- Anthracite | REF: JDNMGN120ANNW



Palma



PALMA 70

☀️ + 🔋 SOLAR & RECHARGEABLE BATTERY

REF: LUMPM070SSNW

- IP65 Outdoor & Indoor use
- ☀️ Solar + Rechargeable Battery (driver not included)
- 💡 Warm Light (included)
- 💡 White Light (included)
- 💡 RGB Light (included)
- lm 600 lm
- 🔋 Remote control (included)

- 📶 Dimmable
- 🌙 Twilight sensor
- 💧 9,1 L
- ☀️ Integrated solar panel
- M Polyethylene
- 📦 Packaging: 35,5 x 35,5 x 70 cm
- 📦 Gross Weight (with packaging): 4,5kg

🔌 CABLE

REF: LUMPM070OFNW

- IP65 Outdoor & Indoor use
- 💡 White Light (included)
- lm 600 lm
- 💧 9,1 L

- M Polyethylene
- 📦 Packaging: 35,5 x 35,5 x 70 cm
- 📦 Gross Weight (with packaging): 4,5kg

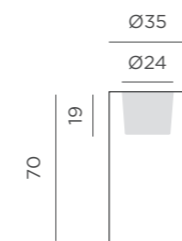

Dimensions (cm)

PALMA 70 | WITHOUT LIGHT

OPAQUE COLOUR

- 💧 9 L
- M Polyethylene
- 📦 Packaging: Plastic bag
- 📦 Gross Weight (with packaging): 4kg

- White | ○ REF: JDNPM070BXNW
- Black | ● REF: JDNPM070NXNW
- Bronze | ● REF: JDNPM070ZXNW
- Taupe | ● REF: JDNPM070KXNW



Melisa 30

MELISA 30 | WITH LIGHT

SOLAR & RECHARGEABLE BATTERY

REF: LUMML030SSNW

- IP65 Outdoor & Indoor use
- Solar + Rechargeable Battery (driver not included)
- Warm Light (included)
- White Light (included)
- RGB Light (included)
- lm 600 lm
- Remote control (included)

- Dimmable
- Twilight sensor
- 6,7 L
- Integrated solar panel
- M Polyethylene
- Packaging: 31 x 31 x 62,3 cm
- Gross Weight (with packaging): 4kg

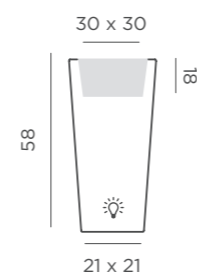

Dimensions (cm)

CABLE

REF: LUMML030OFNW

- IP65 Outdoor & Indoor use
- White Light (included)
- lm 600 lm
- 6,7 L

- M Polyethylene
- Packaging: 31 x 31 x 62,3 cm
- Gross Weight (with packaging): 4kg

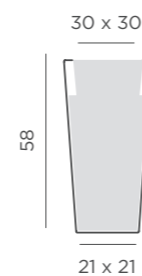

Dimensions (cm)

MELISA 30 | WITHOUT LIGHT

OPAQUE COLOUR

- 11 L
- M Polyethylene
- Packaging: Plastic bag
- Gross Weight (with packaging): 3,5kg

- White | ○ REF: JDNML030BXNW
- Black | ● REF: JDNML030NXNW
- Bronze | ● REF: JDNML030ZXNW
- Taupe | ● REF: JDNML030KNNW
- Terracota | ● REF: JDNML030TNNW
- Anthracite | ● REF: JDNML030ANNW





Melisa 40

MELISA 40 | WITH LIGHT

SOLAR & RECHARGEABLE BATTERY

REF: LUMML040SSNW

- Outdoor & Indoor use
- Solar + Rechargeable Battery (driver not included)
- Warm Light (included)
- White Light (included)
- RGB Light (included)
- 600 lm
- Remote control (included)

- Dimmable
- Twilight sensor
- 11,9 L
- Integrated solar panel
- Polyethylene
- Packaging: 40,5 x 40,5 x 89,5 cm
- Gross Weight (with packaging): 7kg

CABLE

REF: LUMML040FNV

- Outdoor & Indoor use
- White Light (included)
- 600 lm
- Led tube lighting (included)

- 11,9 L
- Polyethylene
- Packaging: 40,5 x 40,5 x 89,5 cm
- Gross Weight (with packaging): 7kg

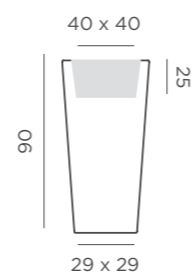

Dimensions (cm)

MELISA 40 | WITHOUT LIGHT

OPAQUE COLOUR

- 11,9 L
- Polyethylene
- Packaging: Plastic bag
- Gross Weight (with packaging): 6kg

- White | **REF: JDNML040BXNW**
- Black | **REF: JDNML040NXNW**
- Bronze | **REF: JDNML040ZXNW**
- Anthracite | **REF: JDNML040ANNW**



Melisa 50

MELISA 50 | WITH LIGHT

SOLAR & RECHARGEABLE BATTERY

REF: LUMML050SSNW

- IP65 Outdoor & Indoor use
- Solar + Rechargeable Battery (driver not included)
- Warm Light (included)
- White Light (included)
- RGB Light (included)
- lm 600 lm
- Remote control (included)

- Dimmable
- Twilight sensor
- 13,9 L
- Integrated solar panel
- M Polyethylene
- Packaging: 50 x 50 x 110 cm
- Gross Weight (with packaging): 11kg

CABLE

REF: LUMML0500FNW

- IP65 Outdoor & Indoor use
- White Light (included)
- lm 600 lm
- Led tube lighting (included)

- 13,9 L
- M Polyethylene
- Packaging: 50 x 50 x 111 cm
- Gross Weight (with packaging): 11kg

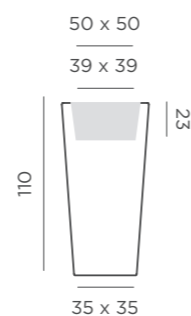

Dimensions (cm)

MELISA 50 | WITHOUT LIGHT

OPAQUE COLOUR

- 13,9 L
- M Polyethylene
- Packaging: 50 x 50 x 111 cm
- Gross Weight (with packaging): 10kg

- White | ○ REF: JDNML050BXNW
- Black | ● REF: JDNML050NXNW
- Bronze | ● REF: JDNML050ZXNW
- Anthracite | ● REF: JDNML050ANNW



Bromelia 28

BROMELIA 28

OPAQUE COLOUR

- 17,2 L
- M Polyethylene
- Integrated wheels
- Packaging: plastic bag
- Gross Weight (with packaging): 2,5kg

- White | ○ REF: JDNBML028BXNLNW
- Anthracite | ● REF: JDNBML028ANLNLW

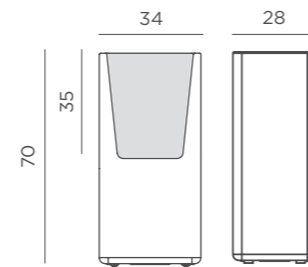

Dimensions (cm)



Bromelia 78

BROMELIA 78

OPAQUE COLOUR

- 41,5 L
- M Polyethylene
- Integrated wheels
- Packaging: plastic bag
- Gross Weight (with packaging): 5kg

- White | ○ REF: JDNBML078BXNLNW
- Anthracite | ● REF: JDNBML078ANLNLW

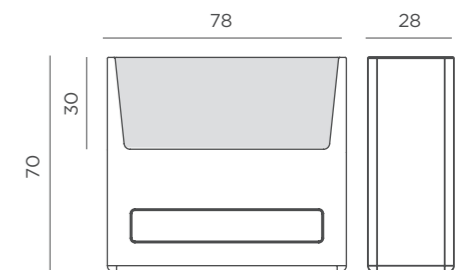

Dimensions (cm)



Junco

JUNCO 80 | WITH LIGHT

☀️ + 🔋 SOLAR & RECHARGEABLE BATTERY

REF: LUMJN0800SSNW

- IP65 Outdoor & Indoor use
- ☀️ Solar + Rechargeable Battery (driver not included)
- 💡 Warm Light (included)
- 💡 White Light (included)
- 💡 RGB Light (included)
- lm 600 lm
- 📶 Remote control (included)

- 📶 Dimmable
- 🌙 Twilight sensor
- 💧 38,8 L
- ☀️ Integrated solar panel
- M Polyethylene
- 📦 Packaging: 38 x 84 x 82,7cm
- 📦 Gross Weight (with packaging): 12kg

🔌 CABLE

REF: LUMJN0800FNW

- IP65 Outdoor & Indoor use
- 💡 White Light (included)
- lm 600 lm
- 💧 38,8 L

- M Polyethylene
- 📦 Packaging: 38 x 84 x 82,7 cm
- 📦 Gross Weight (with packaging): 12kg

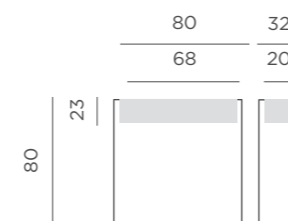

Dimensions (cm)

JUNCO 80 | WITHOUT LIGHT

OPAQUE COLOUR

- 💧 38,8 L
- M Polyethylene
- 📦 Packaging: Plastic bag
- 📦 Gross Weight (with packaging): 10kg

- White | ○ REF: JDNJN080BXNW
- Black | ● REF: JDNJN080NXNW
- Bronze | ● REF: JDNJN080ZXNW
- Taupe | ● REF: JDNJN080KXNW
- Anthracite | ● REF: JDNJN080ANNW





Jara

JARA 60X20

- 🍷 12,4 L
- M** Polyethylene
- 📦 Packaging: Plastic bag
- 📦 Gross Weight (with packaging): 1,5kg

- White | ○ **REF: JDNJR060BXNW**
- Black | ● **REF: JDNJR060NXNW**
- Bronze | ● **REF: JDNJR060ZXNW**
- Taupe | ● **REF: JDNJR060KXNW**
- Terracota | ● **REF: JDNJR060TXNW**
- Anthracite | ● **REF: JDNJR060ANNW**

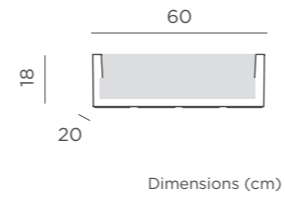

JARA 100X35

- 🍷 51,7 L
- 🌊 Includes water reservoir
- M** Polyethylene
- 📦 Packaging: Plastic bag
- 📦 Gross Weight (with packaging): 7kg

- White | ○ **REF: JDNJR100BXNW**
- Black | ● **REF: JDNJR100NXNW**
- Bronze | ● **REF: JDNJR100ZXNW**
- Taupe | ● **REF: JDNJR100KXNW**
- Terracota | ● **REF: JDNJR100TXNW**
- Anthracite | ● **REF: JDNJR100ANNW**

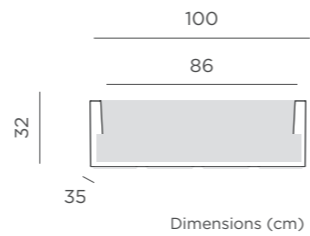

JARA 100X40

- 🍷 60,7 L
- 🌊 Includes water reservoir
- M** Polyethylene
- 📦 Packaging: Plastic bag
- 📦 Gross Weight (with packaging): 8kg

- White | ○ **REF: JDNJR140BXNW**
- Black | ● **REF: JDNJR140NXNW**
- Bronze | ● **REF: JDNJR140ZXNW**
- Taupe | ● **REF: JDNJR140KXNW**
- Terracota | ● **REF: JDNJR140TXNW**
- Anthracite | ● **REF: JDNJR140ANNW**

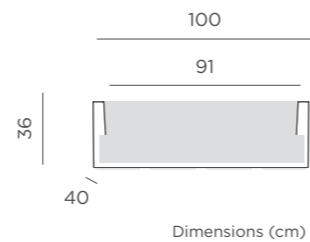



Olivo 50

OLIVO 50

OPAQUE COLOUR

- 🍷 105 L
- 🏠 Includes water reservoir
- M** Polyethylene
- 📦 Packaging: Plastic bag
- 📦 Gross Weight (with packaging): 5,5 kg

- White | ○ REF: JDNOLIO50BXNLNW
- Anthracite | ● REF: JDNOLIO50ANLNLW

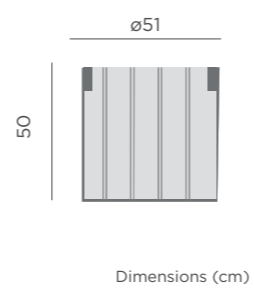

Olivo high

OLIVO HIGH

OPAQUE COLOUR

- 🍷 205 L
- M** Polyethylene
- 📦 Packaging: Plastic bag
- 📦 Gross Weight (with packaging): 10kg

- White | ○ REF: JDNOLIO90BXNLNW
- Anthracite | ● REF: JDNOLIO90ANLNLW

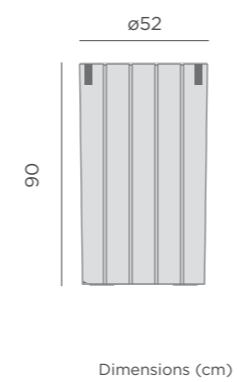



Olivo large

OLIVO LARGE

OPAQUE COLOUR

- 🚰 252 L
- 🌊 Includes water reservoir
- M** Polyethylene
- 📦 Packaging: Plastic bag
- 📦 Gross Weight (with packaging): 12kg

- White | ○ REF: JDNOLI120BXNLNW
- Anthracite | ● REF: JDNOLI120ANNLNW

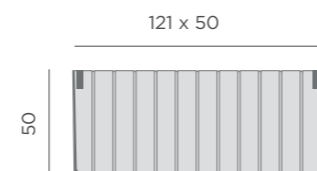

Dimensions (cm)

Narciso 35

NARCISO 35

- 17,4 L
- M Polyethylene
- Packaging: Plastic bag
- Gross Weight (with packaging): 2kg

- White | ○ REF: JDNNC035BXNW
- Black | ● REF: JDNNC035NXNW
- Bronze | ● REF: JDNNC035ZXNW
- Taupe | ● REF: JDNNC035KXNW
- Terracota | ● REF: JDNNC035TXNW
- Anthracite | ● REF: JDNNC035ANNW

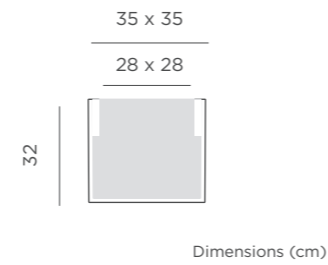

Narciso 40

NARCISO 40 | WITH LIGHT

SOLAR & RECHARGEABLE BATTERY

REF: LUMNC040SSNW

- IP65 Outdoor & Indoor use
- Solar + Rechargeable Battery (driver not included)
- Warm Light (included)
- White Light (included)
- RGB Light (included)
- 600 lm
- Remote control (included)

- Dimmable
- Twilight sensor
- 15,3 L
- Integrated solar panel
- M Polyethylene
- Packaging: 40,5 x 40,5 x 40 cm
- Gross Weight (with packaging): 3,5kg

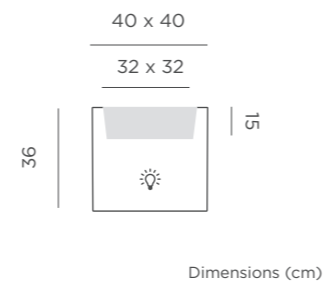

NARCISO 40 | WITHOUT LIGHT

OPAQUE COLOUR

- 27,8 L
- Includes water reservoir
- M Polyethylene
- Packaging: Plastic bag
- Gross Weight (with packaging): 2,5kg

- White | ○ REF: JDNNC040BXNW
- Black | ● REF: JDNNC040NXNW
- Bronze | ● REF: JDNNC040ZXNW
- Terracota | ● REF: JDNNC040TXNW
- Anthracite | ● REF: JDNNC040ANNW

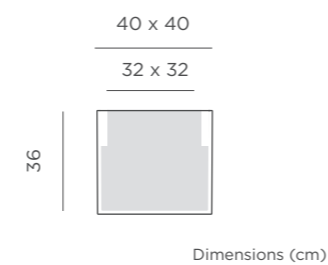







Narciso 50

NARCISO 50 | WITH LIGHT

  SOLAR & RECHARGEABLE BATTERY

REF: LUMNC050SSNW



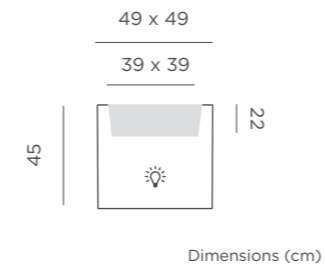

- IP65 Outdoor & Indoor use
-  Solar + Rechargeable Battery (driver not included)
-  Warm Light (included)
-  White Light (included)
-  RGB Light (included)
- Im 600 lm
-  Remote control (included)

-  Dimmable
-  Twilight sensor
-  33 L
-  Integrated solar panel
- M** Polyethylene
-  Packaging: 59 x 59 x 59 cm
-  Gross Weight (with packaging): 6,5kg



NARCISO 50 | WITHOUT LIGHT

OPAQUE COLOUR

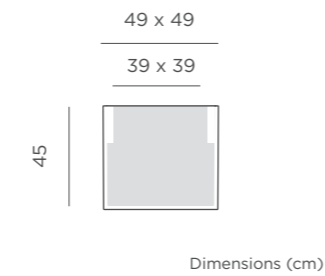

-  53,8 L
-  Includes water reservoir
- M** Polyethylene
-  Packaging: Plastic bag
-  Gross Weight (with packaging): 5kg

- White | REF: JDNNC050BXNW
- Black | REF: JDNNC050NXNW
- Bronze | REF: JDNNC050ZXNW
- Terracota | REF: JDNNC050TXNW
- Anthracite | REF: JDNNC050ANNW



Narciso 60

NARCISO 60

-  84,8 L
- M** Polyethylene
-  Packaging: Plastic bag
-  Gross Weight (with packaging): 7kg

- White | REF: JDNNC060BXNW
- Black | REF: JDNNC060NXNW
- Bronze | REF: JDNNC060ZXNW
- Anthracite | REF: JDNNC060ANNW

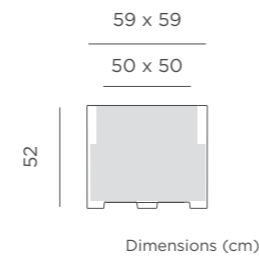

Jazmín



JAZMÍN 60

- 🌿 21,5 L
- 🏠 Includes water reservoir
- M** Polyethylene
- 📦 Packaging: Plastic bag
- 📦 Gross Weight (with packaging): 2kg

- White | ○ **REF: JDNJZ060BXNW**
- Black | ● **REF: JDNJZ060NXNW**
- Bronze | ● **REF: JDNJZ060ZXNW**
- Terracota | ● **REF: JDNJZ060TXNW**
- Anthracite | ● **REF: JDNJZ060ANNW**

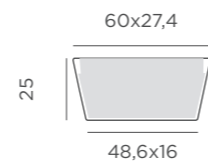

Dimensions (cm)

JAZMÍN 80

- 🌿 58,7 L
- 🏠 Includes water reservoir | Plate included
- M** Polyethylene
- 📦 Packaging: Plastic bag
- 📦 Gross Weight (with packaging): 4kg

- White | ○ **REF: JDNJZ080BXNW**
- Black | ● **REF: JDNJZ080NXNW**
- Bronze | ● **REF: JDNJZ080ZXNW**
- Terracota | ● **REF: JDNJZ080TXNW**
- Anthracite | ● **REF: JDNJZ080ANNW**

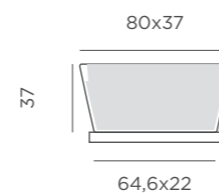

Dimensions (cm)

Clavel



CLAVEL 30

- 🌿 5,2 L
- M** Polyethylene
- 📦 Packaging: Plastic bag
- 📦 Gross Weight (with packaging): 1,2kg

- White | ○ **REF: JDNCV030BXNW**
- Black | ● **REF: JDNCV030NXNW**
- Bronze | ● **REF: JDNCV030ZXNW**
- Taupe | ● **REF: JDNCV030KXNW**
- Terracota | ● **REF: JDNCV030TXNW**
- Anthracite | ● **REF: JDNCV030ANNW**

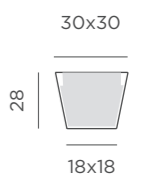

Dimensions (cm)

CLAVEL 40

- 🌿 12,3 L
- M** Polyethylene
- 📦 Packaging: Plastic bag
- 📦 Gross Weight (with packaging): 2,5kg

- White | ○ **REF: JDNCV040BXNW**
- Black | ● **REF: JDNCV040NXNW**
- Bronze | ● **REF: JDNCV040ZXNW**
- Terracota | ● **REF: JDNCV040TXNW**
- Anthracite | ● **REF: JDNCV040ANNW**

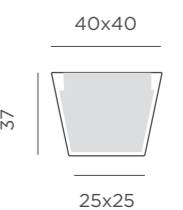

Dimensions (cm)

Camomila



Petunia



CAMOMILA RÚSTICA

- 44 L
- Polyethylene
- Packaging: Plastic bag
- Gross Weight (with packaging): 2.5kg

- White | ○ REF: JDNCM040BXNW
- Black | ● REF: JDNCM040NXNW
- Bronze | ● REF: JDNCM040ZXNW
- Taupe | ● REF: JDNCM040KXNW
- Terracota | ● REF: JDNCM040TXNW
- Anthracite | ● REF: JDNCM040ANNW



Dimensions (cm)

PETUNIA RÚSTICA

- 17.3 L
- Polyethylene
- Packaging: Plastic bag
- Gross Weight (with packaging): 1kg

- White | ○ REF: JDNPT036BXNW
- Black | ● REF: JDNPT036NXNW
- Bronze | ● REF: JDNPT036ZXNW
- Taupe | ● REF: JDNPT036KXNW
- Terracota | ● REF: JDNPT036TXNW
- Anthracite | ● REF: JDNPT036ANNW

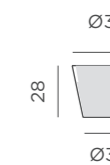

Dimensions (cm)

VIOLETA 30

- 12,5 L
- Includes water reservoir
- M Polyethylene
- Packaging: Plastic bag
- Gross Weight (with packaging): 1kg

- White | ○ REF: JDNVLO30BXNW
- Black | ● REF: JDNVLO30NXNW
- Bronze | ● REF: JDNVLO30ZXNW
- Taupe | ● REF: JDNVLO30KXNW
- Terracota | ● REF: JDNVLO30TXNW
- Anthracite | ● REF: JDNVLO30ANNW

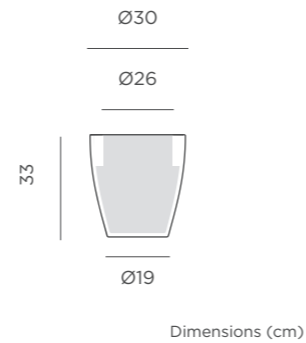

VIOLETA 40 | WITH LIGHT

SOLAR & RECHARGEABLE BATTERY

REF: LUMVLO40SSNW

- IP65 Outdoor & Indoor use
- Solar + Rechargeable Battery (driver not included)
- Warm Light (included)
- White Light (included)
- RGB Light (included)
- Im 600 lm
- Remote control (included)

- Dimmable
- Twilight sensor
- 14,5 L
- Integrated solar panel
- M Polyethylene
- Packaging: 46 x 46 x 46,5 cm
- Gross Weight (with packaging): 3kg

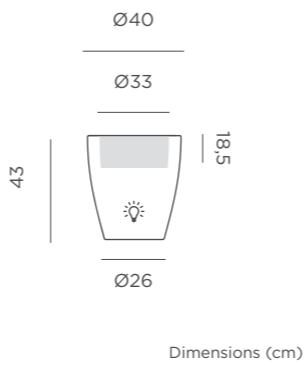

VIOLETA 40 | WITHOUT LIGHT

OPAQUE COLOUR

- 30,6 L
- Includes water reservoir
- M Polyethylene
- Packaging: Plastic bag
- Gross Weight (with packaging): 2kg

- White | ○ REF: JDNVLO40BXNW
- Black | ● REF: JDNVLO40NXNW
- Bronze | ● REF: JDNVLO40ZXNW
- Taupe | ● REF: JDNVLO40KXNW
- Terracota | ● REF: JDNVLO40TXNW
- Anthracite | ● REF: JDNVLO40ANNW

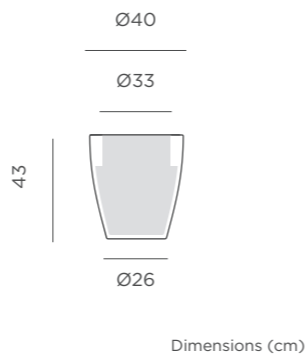

VIOLETA 55 | WITH LIGHT

SOLAR & RECHARGEABLE BATTERY

REF: LUMVLO55SSNW

- IP65 Outdoor & Indoor use
- Rechargeable Battery Electric Charge (driver not included)
- Warm Light (included)
- White Light (included)
- RGB Light (included)
- Im 600 lm
- Remote control (included)

- Dimmable
- Twilight sensor
- 34,7 L
- Integrated solar panel
- M Polyethylene
- Packaging: 59 x 59 x 59 cm
- Gross Weight (with packaging): 5,5kg

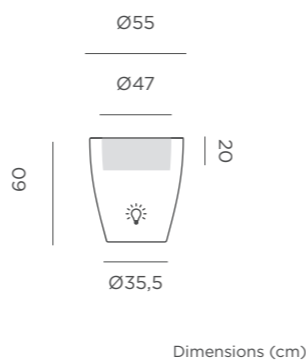

VIOLETA 55 | WITHOUT LIGHT

OPAQUE COLOUR

- 68,2 L
- Includes water reservoir
- M Polyethylene
- Packaging: Plastic bag
- Gross Weight (with packaging): 4kg

- White | ○ REF: JDNVLO55BXNW
- Black | ● REF: JDNVLO55NXNW
- Bronze | ● REF: JDNVLO55ZXNW
- Terracota | ● REF: JDNVLO55TXNW
- Anthracite | ● REF: JDNVLO55ANNW

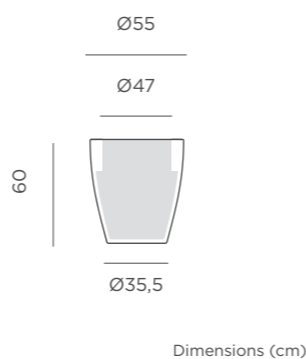

Violeta



Gerbera 33

GERBERA 33

- 19,6 L
- Includes water reservoir
- M Polyethylene
- Packaging: Plastic bag
- Gross Weight (with packaging): 1,2kg

- White | ○ REF: JDNGB033BXNW
- Black | ● REF: JDNGB033NXNW
- Bronze | ● REF: JDNGB033ZXNW
- Taupe | ● REF: JDNGB033KXNW
- Terracota | ● REF: JDNGB033TXNW
- Anthracite | ● REF: JDNGB033ANNW

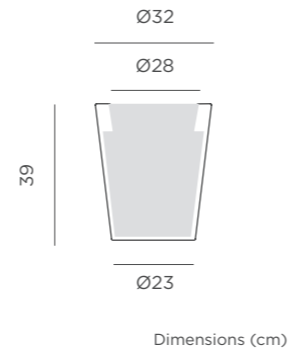

Gerbera 45

GERBERA 45

- 54,8 L
- Includes water reservoir
- M Polyethylene
- Packaging: Plastic bag
- Gross Weight (with packaging): 2,5kg

- White | ○ REF: JDNGB045BXNW
- Black | ● REF: JDNGB045NXNW
- Bronze | ● REF: JDNGB045ZXNW
- Taupe | ● REF: JDNGB045KXNW
- Terracota | ● REF: JDNGB045TXNW
- Anthracite | ● REF: JDNGB045ANNW

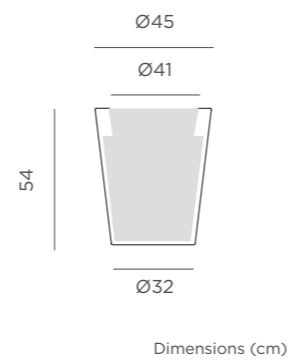

Gerbera 50

GERBERA 50 | RUSTIC TEXTURE

- 72,8 L
- Includes water reservoir
- M Polyethylene
- Packaging: Plastic bag
- Gross Weight (with packaging): 4kg

- White | ○ REF: JDNGB050BXNW
- Black | ● REF: JDNGB050NXNW
- Bronze | ● REF: JDNGB050ZXNW
- Terracota | ● REF: JDNGB050TXNW
- Anthracite | ● REF: JDNGB050ANNW

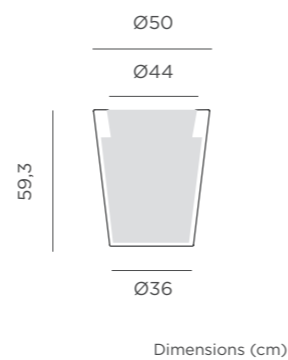



Girasol



Caléndula

GIRASOL BIG SIZE

- 🌿 313 L
- M** Polyethylene
- 📦 Packaging: Plastic bag
- 📦 Gross Weight (with packaging): 14kg

- White | ○ **REF: JDNGL090BXNW**
- Black | ● **REF: JDNGL090NXNW**
- Bronze | ● **REF: JDNGL090ZXNW**
- Terracota | ● **REF: JDNGL090TXNW**
- Anthracite | ● **REF: JDNGL090ANNW**

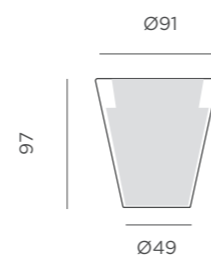

Dimensions (cm)

CALÉNDULA RÚSTICA

- 🌿 49,7 L
- M** Polyethylene
- 📦 Packaging: Plastic bag
- 📦 Gross Weight (with packaging): 6kg

- White | ○ **REF: JDNCL050BXNW**
- Black | ● **REF: JDNCL050NXNW**
- Bronze | ● **REF: JDNCL050ZXNW**
- Terracota | ● **REF: JDNCL050TXNW**
- Anthracite | ● **REF: JDNCL050ANNW**

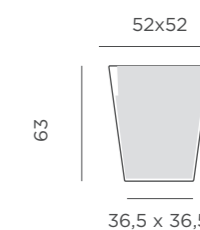

Dimensions (cm)

Rosa

ROSA 45

- 🍷 26 L
- M** Polyethylene
- 📦 Packaging: Plastic bag
- 📦 Gross Weight (with packaging): 1,5kg

- White | ○ **REF: JDNRS045BXNW**
- Black | ● **REF: JDNRS045NXNW**
- Bronze | ● **REF: JDNRS045ZXNW**
- Terracota | ● **REF: JDNRS045TXNW**
- Anthracite | ● **REF: JDNRS045ANNW**

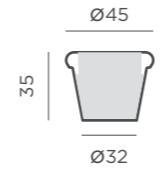

Dimensions (cm)

ROSA 55

- 🍷 42,8 L
- M** Polyethylene
- 📦 Packaging: Plastic bag
- 📦 Gross Weight (with packaging): 2,3kg

- White | ○ **REF: JDNRS055BXNW**
- Black | ● **REF: JDNRS055NXNW**
- Bronze | ● **REF: JDNRS055ZXNW**
- Terracota | ● **REF: JDNRS055TXNW**
- Anthracite | ● **REF: JDNRS055ANNW**



Dimensions (cm)

ROSA 65

- 🍷 79 L
- M** Polyethylene
- 📦 Packaging: Plastic bag
- 📦 Gross Weight (with packaging): 3kg

- White | ○ **REF: JDNRS065BXNW**
- Black | ● **REF: JDNRS065NXNW**
- Bronze | ● **REF: JDNRS065ZXNW**
- Terracota | ● **REF: JDNRS065TXNW**
- Anthracite | ● **REF: JDNRS065ANNW**

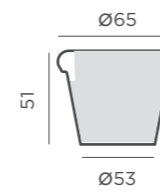

Dimensions (cm)

ROSA 75

- 🍷 121 L
- M** Polyethylene
- 📦 Packaging: Plastic bag
- 📦 Gross Weight (with packaging): 5kg

- White | ○ **REF: JDNRS075BXNW**
- Black | ● **REF: JDNRS075NXNW**
- Bronze | ● **REF: JDNRS075ZXNW**
- Taupe | ● **REF: JDNRS075KXNW**
- Terracota | ● **REF: JDNRS075TXNW**
- Anthracite | ● **REF: JDNRS075ANNW**



Dimensions (cm)



Wally pots



WALLY SQUARE POT 12X12X12

REF: JDNWAP012BXNLNW

- IP65 Outdoor use
- Artificial plants included
- 1,33 L

- M Recycled Plastic
- ☞ Packaging: 13,5 x 12,8 x 12,8 cm
- 📦 Gross Weight (with packaging): 0,4kg



Dimensions (cm)

WALLY SQUARE POT 18X18X18

REF: JDNWAP018BXNLNW

- IP65 Outdoor use
- Artificial plants included
- 1,8 L

- M Recycled Plastic
- ☞ Packaging: 19,5 x 19 x 19,5 cm
- 📦 Gross Weight (with packaging): 0,72kg



Dimensions (cm)

Solar Wally (lighting collection) also available | pag. 107



Plates

ROUNDED PLATE 30

Compatible with: Violeta 40, Magnolia 45, Rosa 45, Bambú 70, Bambú 90, Petunia, Hortensia 30 y Dalia 30.

- White | ○ REF: JDNPR030BXNW
- Black | ● REF: JDNPR030XNW
- Bronze | ● REF: JDNPR030ZXNW
- Taupe | ● REF: JDNPR030KXNW
- Terracota | ● REF: JDNPR030TXNW
- Anthracite | ● REF: JDNPR030ANNW

31.5x31.5

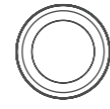

Ø37

Dimensions (cm)

ROUNDED PLATE 40

Compatible with: Violeta 55, Magnolia 60, Rosa 55, Gerbera 45, Azalea 50, Dalia 50.

- White | ○ REF: JDNPR040BXNW
- Black | ● REF: JDNPR040XNW
- Bronze | ● REF: JDNPR040ZXNW
- Taupe | ● REF: JDNPR040KXNW
- Terracota | ● REF: JDNPR040TXNW
- Anthracite | ● REF: JDNPR040ANNW

41x41

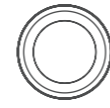

Ø49

Dimensions (cm)

SQUARED PLATE 40

Compatible with: Caléndula 50, Melisa 50, Narciso 35.

- White | ○ REF: JDNPC040BXNW
- Black | ● REF: JDNPC040XNW
- Bronze | ● REF: JDNPC040ZXNW
- Taupe | ● REF: JDNPC040KXNW
- Terracota | ● REF: JDNPC040TXNW
- Anthracite | ● REF: JDNPC040ANNW

40x40



47x47

Dimensions (cm)

SQUARED PLATE 50

Compatible with: Narciso 50.

- White | ○ REF: JDNPC050BXNW
- Black | ● REF: JDNPC050XNW
- Bronze | ● REF: JDNPC050ZXNW
- Taupe | ● REF: JDNPC050KXNW
- Terracota | ● REF: JDNPC050TXNW
- Anthracite | ● REF: JDNPC050ANNW

52x52



61.5x61.5

Dimensions (cm)



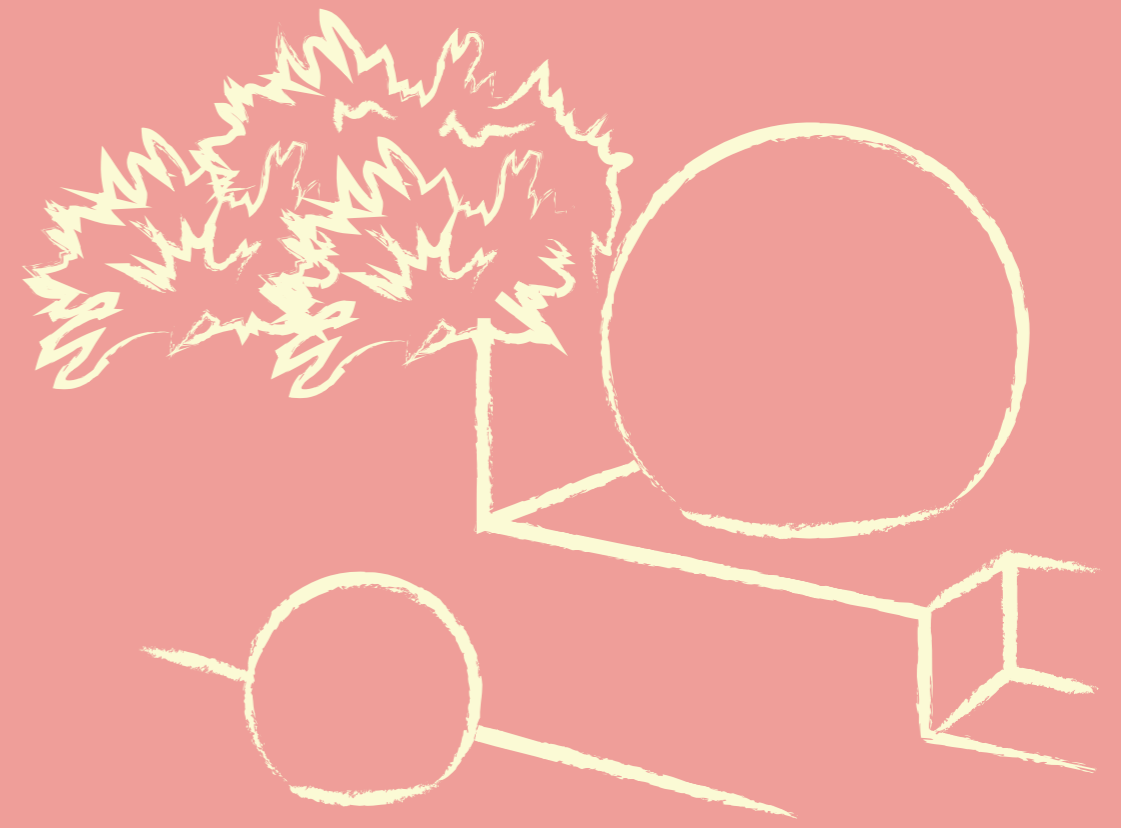

Light and Deco

Buly Collection



Buly Collection

BULY

☀️ + 🔋 SOLAR & RECHARGEABLE BATTERY

<p>IP65 Outdoor & Indoor use</p> <ul style="list-style-type: none"> ☀️ Solar + Rechargeable battery* 💡 Warm Light (included) 💡 White Light (included) 💡 RGB Light (included) Im 600 lm 📱 Remote control (included) 📊 Dimmable ☀️ Integrated solar panel 🌙 Twilight sensor M Polyethylene 				
	Buly 20	<p>REF: LUMBLO20SSNW</p> <ul style="list-style-type: none"> 📦 Packaging: 20,3 x 20,3 x 19,5 cm 📊 Gross Weight (with packaging): 0,71kg 	Buly 50	<p>REF: LUMBLO50SSNW</p> <ul style="list-style-type: none"> 📦 Packaging: 44,5 x 50,5 x 50,5 cm 📊 Gross Weight (with packaging): 3,2kg
	Buly 30	<p>REF: LUMBLO30SSNW</p> <ul style="list-style-type: none"> 📦 Packaging: 30,3 x 30,3 x 28,5 cm 📊 Gross Weight (with packaging): 1,2kg 	Buly 60	<p>REF: LUMBLO60SSNW</p> <ul style="list-style-type: none"> 📦 Packaging: 56 x 59,5 x 59,5 cm 📊 Gross Weight (with packaging): 4,5kg
	Buly 40	<p>REF: LUMBLO40SSNW</p> <ul style="list-style-type: none"> 📦 Packaging: 36,6 x 40,3 x 40,3 cm 📊 Gross Weight (with packaging): 1,9kg 	Buly 80	<p>REF: LUMBLO80SSNW</p> <ul style="list-style-type: none"> 📦 Packaging: 70,3 x 79,5 x 79,5 cm 📊 Gross Weight (with packaging): 9,5kg

☀️ SOLAR (FLOATING)

<p>IP68 Outdoor & Indoor use</p> <ul style="list-style-type: none"> ☀️ Solar + Rechargeable battery* 💡 Warm Light (included) 💡 White Light (included) 💡 RGB Light (included) Im 600 lm 📱 Remote control (included) 📊 Dimmable 🌙 Twilight sensor 🚢 Floating, not submersible ☀️ Integrated solar panel M Polyethylene 				
	Buly 20	<p>REF: LUMBLO20FTNW</p> <ul style="list-style-type: none"> 📦 Packaging: 20,3 x 20,3 x 19,5 cm 📊 Gross Weight (with packaging): 0,8kg 		
	Buly 30	<p>REF: LUMBLO30FTNW</p> <ul style="list-style-type: none"> 📦 Packaging: 31,5 x 31,5 x 29 cm 📊 Gross Weight (with packaging): 1,2kg 		
	Buly 40	<p>REF: LUMBLO40FTNW</p> <ul style="list-style-type: none"> 📦 Packaging: 36,6 x 40,3 x 40,3 cm 📊 Gross Weight (with packaging): 1,9kg 		

☀️ SOLAR AUTOMATIC (BULY AUTONOMOUS)

<p>IP65 Outdoor use</p> <ul style="list-style-type: none"> ☀️ Solar Charge 💡 RGB Light (included) 💡 White Light (included) Im 50 lm 🌙 Twilight sensor ☀️ Integrated solar panel M Polyethylene 		
	Buly 20	<p>REF: LUMBLO20SANW</p> <ul style="list-style-type: none"> 📦 Packaging: 20,3 x 20,3 x 19,5 cm 📊 Gross Weight (with packaging): 0,8kg

🔌 CABLE (WARM LIGHT)

<p>IP65 Outdoor & Indoor use</p> <ul style="list-style-type: none"> 💡 Warm Light (included) Im 600 lm Buly 20: 250 lm M Polyethylene 				
	Buly 20	<p>REF: LUMBLO20OCNW</p> <ul style="list-style-type: none"> 📦 Packaging: 20,3 x 20,3 x 19,5 cm 📊 Gross Weight (with packaging): 0,8kg 	Buly 50	<p>REF: LUMBLO50OCNW</p> <ul style="list-style-type: none"> 📦 Packaging: 44,5 x 50,5 x 50,5 cm 📊 Gross Weight (with packaging): 3,2kg
	Buly 30	<p>REF: LUMBLO30OCNW</p> <ul style="list-style-type: none"> 📦 Packaging: 31,8 x 31,8 x 29,3 cm 📊 Gross Weight (with packaging): 1,2kg 	Buly 60	<p>REF: LUMBLO60OCNW</p> <ul style="list-style-type: none"> 📦 Packaging: 56 x 59,5 x 59,5 cm 📊 Gross Weight (with packaging): 4,5kg
	Buly 40	<p>REF: LUMBLO40OCNW</p> <ul style="list-style-type: none"> 📦 Packaging: 40,3 x 40,3 x 36,6 cm 📊 Gross Weight (with packaging): 1,9kg 	Buly 80	<p>REF: LUMBLO80OCNW</p> <ul style="list-style-type: none"> 📦 Packaging: 79,5 x 79,5 x 70,3 cm 📊 Gross Weight (with packaging): 9,5kg

🔌 CABLE (WHITE LIGHT)

<p>IP65 Outdoor & Indoor use</p> <ul style="list-style-type: none"> 💡 White Light (included) Im 600 lm Buly 20: 250 lm M Polyethylene 				
	Buly 20	<p>REF: LUMBLO20OFNW</p> <ul style="list-style-type: none"> 📦 Packaging: 20,3 x 20,3 x 19,5 cm 📊 Gross Weight (with packaging): 0,8kg 	Buly 50	<p>REF: LUMBLO50OFNW</p> <ul style="list-style-type: none"> 📦 Packaging: 50,8 x 50,8 x 45,3cm 📊 Gross Weight (with packaging): 3,2kg
	Buly 30	<p>REF: LUMBLO30OFNW</p> <ul style="list-style-type: none"> 📦 Packaging: 31,5 x 31,5 x 29 cm 📊 Gross Weight (with packaging): 1,2kg 	Buly 60	<p>REF: LUMBLO60OFNW</p> <ul style="list-style-type: none"> 📦 Packaging: 60 x 60 x 57 cm 📊 Gross Weight (with packaging): 4,5kg
	Buly 40	<p>REF: LUMBLO40OFNW</p> <ul style="list-style-type: none"> 📦 Packaging: 40,3 x 40,3 x 36,6 cm 📊 Gross Weight (with packaging): 1,9kg 	Buly 80	<p>REF: LUMBLO80OFNW</p> <ul style="list-style-type: none"> 📦 Packaging: 79,5 x 79,5 x 70,3 cm 📊 Gross Weight (with packaging): 9,5kg

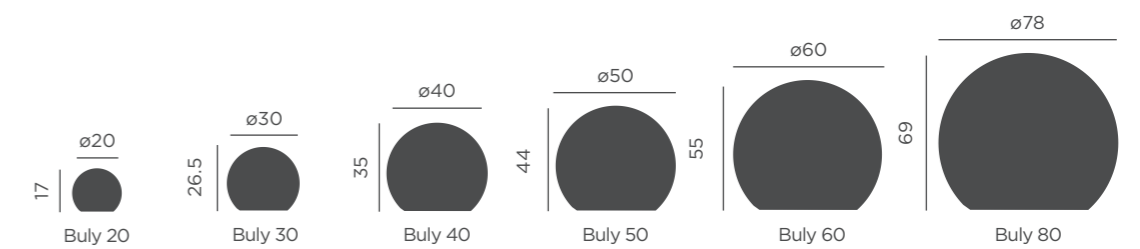

Dimensions (cm)

(*) Power adapter not included

Cuby Collection

CUBY

SOLAR & RECHARGEABLE BATTERY

- IP65 Outdoor & Indoor use
- Solar + Rechargeable battery *
- Warm Light (included)
- White Light (included)
- RGB Light (included)
- lm 600 lm
- Remote control (included)
- Dimmable
- Twilight sensor
- Integrated solar panel
- M** Polyethylene

Cuby 20

REF: LUMCB020SSNW

- Packaging: 26,5 x 30,3 x 30,3 cm
- Gross Weight (with packaging): 1,1kg

Cuby 32

REF: LUMCB032SSNW

- Packaging: 34,8 x 32,5 x 32,5 cm
- Gross Weight (with packaging): 2,7kg

Cuby 40

REF: LUMCB040SSNW

- Packaging: 42 x 40,6 x 40,6 cm
- Gross Weight (with packaging): 4kg

Cuby 45

REF: LUMCB045SSNW

- Packaging: 45 x 43,5 x 43,5 cm
- Gross Weight (with packaging): 5kg

Cuby 53

REF: LUMCB053SSNW

- Packaging: 43,6 x 43,6 x 55 cm
- Gross Weight (with packaging): 5,5kg

CABLE (WARM LIGHT)

- IP65 Outdoor & Indoor use
- Warm Light (included)
- lm 600 lm
- M** Polyethylene

Cuby 32

REF: LUMCB032OCNW

- Packaging: 34,8 x 32,5 x 32,5 cm
- Gross Weight (with packaging): 2,7kg

Cuby 40

REF: LUMCB040CFNW

- Packaging: 42 x 40,6 x 40,6 cm
- Gross Weight (with packaging): 4kg

Cuby 45

REF: LUMCB045OCNW

- Packaging: 45 x 43,5 x 43,5 cm
- Gross Weight (with packaging): 5kg

CABLE (WHITE LIGHT)

- IP65 Outdoor & Indoor use
- White Light (included)
- lm 600 lm | Cuby 20: 250 lm
- M** Polyethylene

Cuby 20

REF: LUMCB0200FNW

- Packaging: 26,5 x 30,3 x 30,3 cm
- Gross Weight (with packaging): 1,1kg

Cuby 32

REF: LUMCB0320FNW

- Packaging: 34,8 x 32,5 x 32,5 cm
- Gross Weight (with packaging): 2,7kg

Cuby 40

REF: LUMCB0400FNW

- Packaging: 42 x 40,6 x 40,6 cm
- Gross Weight (with packaging): 4,5kg

Cuby 45

REF: LUMCB0450FNW

- Packaging: 45 x 43,5 x 43,5 cm
- Gross Weight (with packaging): 5kg

Cuby 53

REF: LUMCB0530FNW

- Packaging: 43,6 x 43,6 x 55 cm
- Gross Weight (with packaging): 5,5kg

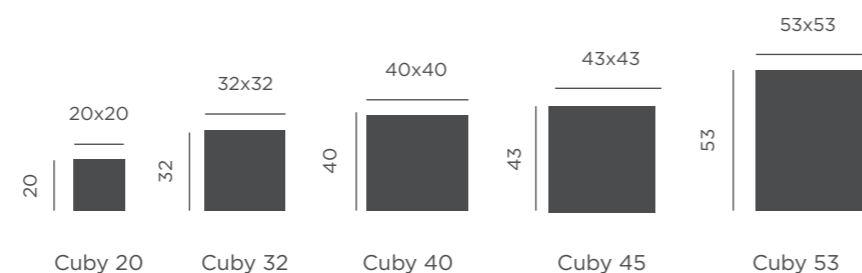

Dimensions (cm)

(*) Power adapter not included



Lighting collection

+ Ask us and discover our complete lighting Collection.

PRODUCTS

(1) LOLA 110 (2) FITY (3) PETRA (4) CHERRY (5) CHERRY MINI (6) BANANA (7) LIMA (8) COCO

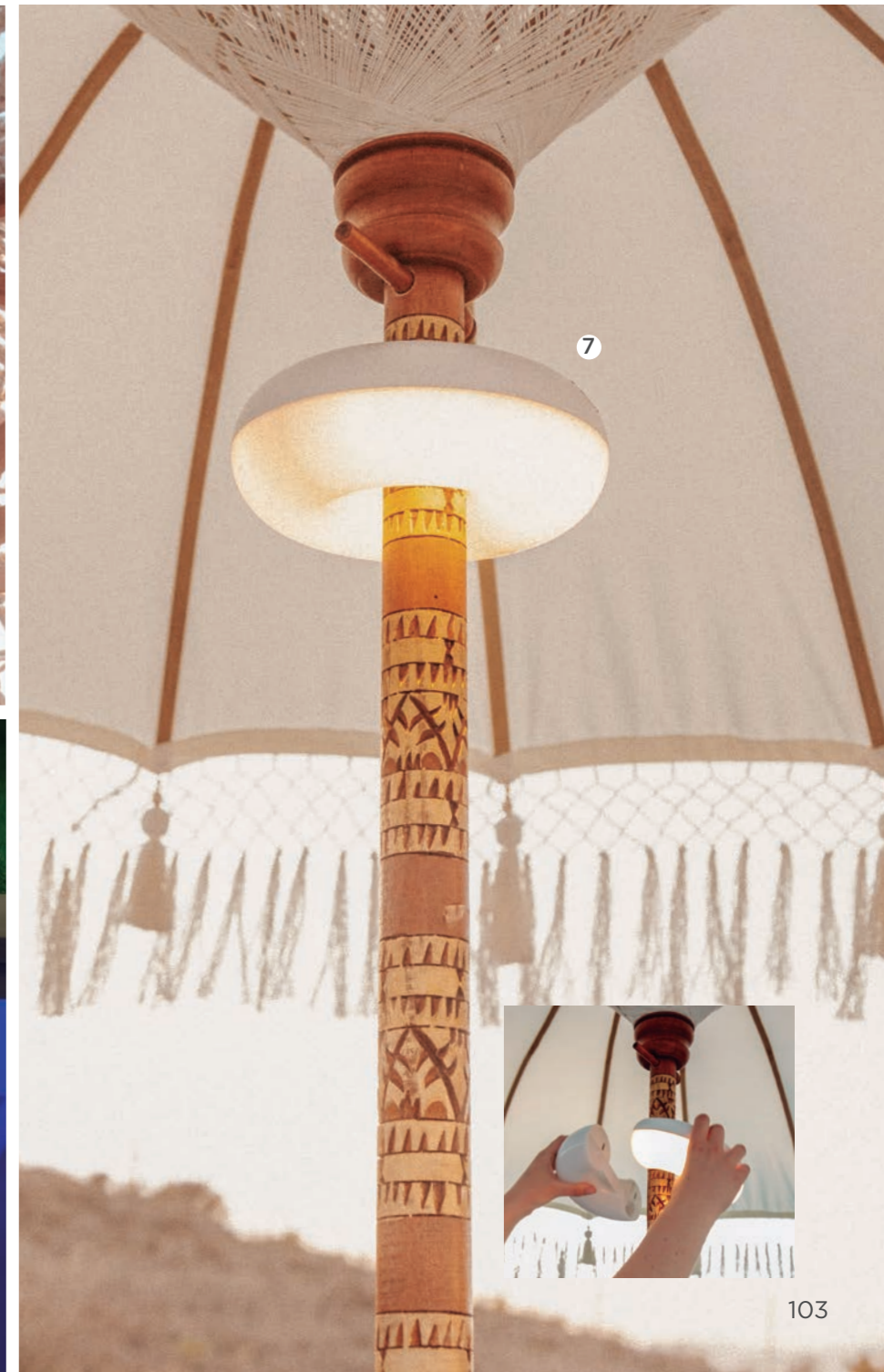



+ Ask us and discover our complete lighting Collection.

PRODUCTS
(1) GRETITA PICA (2) GRETA (3) HIAMA (4) GRETITA MESA (5) CANDY (6) VEGA
(7) JACK (8) DOLO CERAMIC (9) LOLA 12 LUX

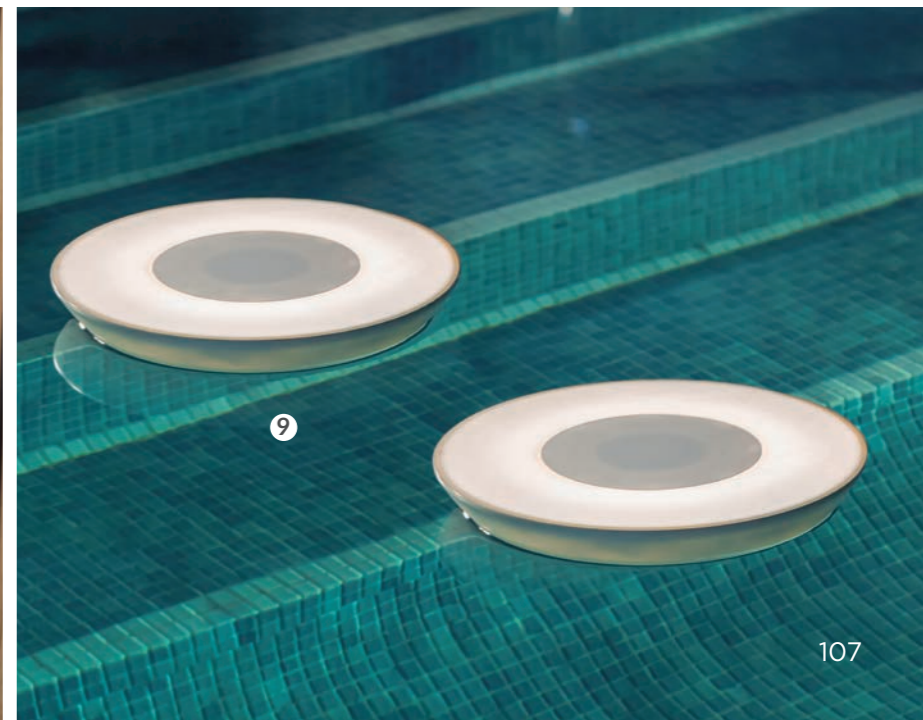
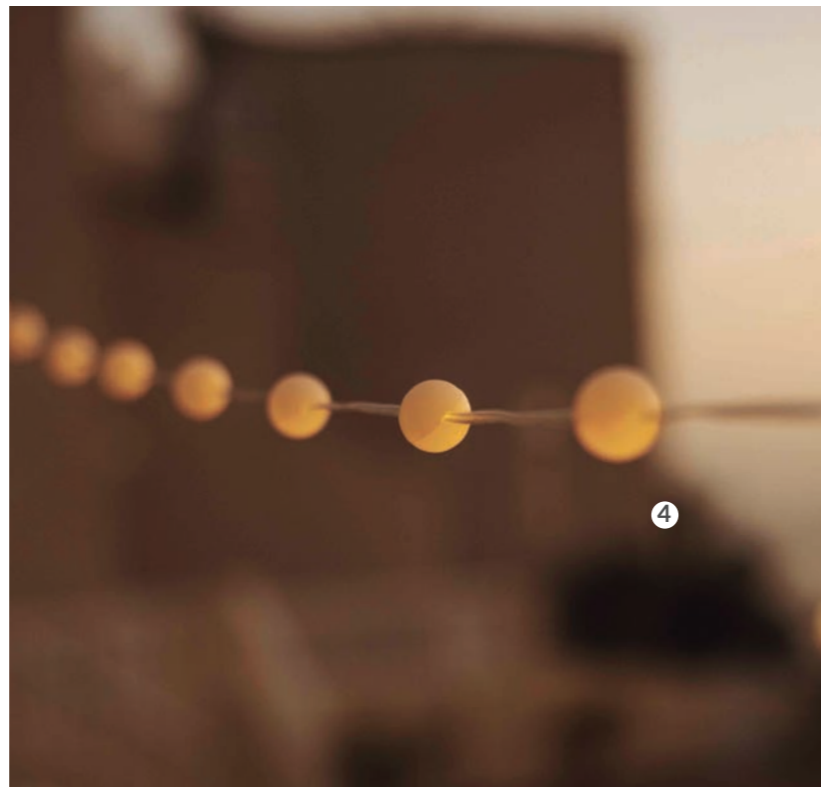
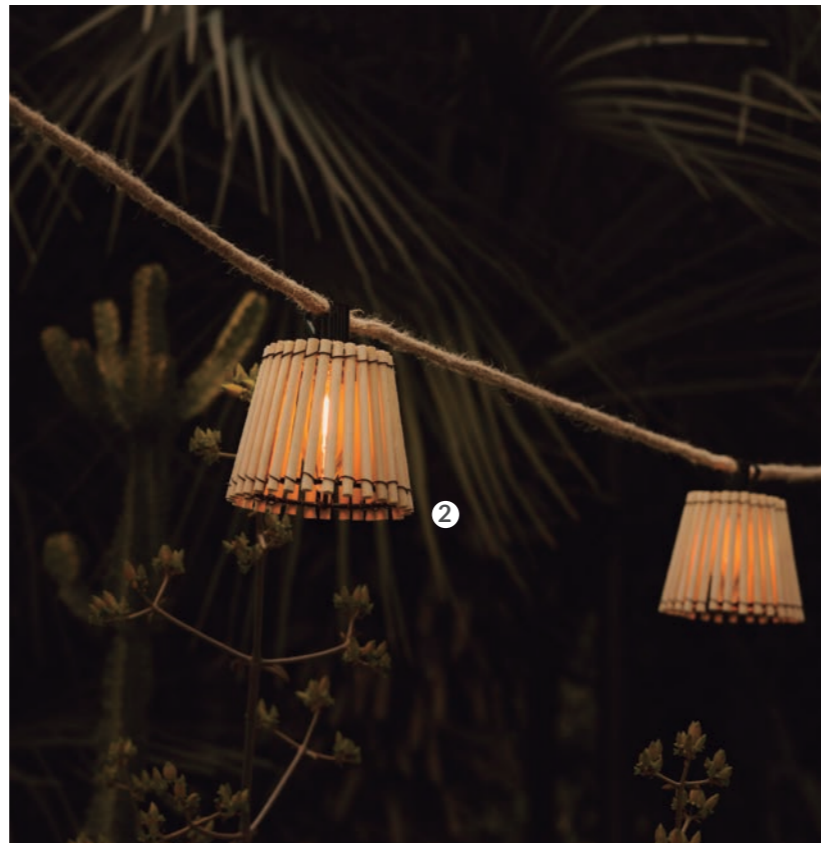

































+ Ask us and discover our complete lighting Collection.



PRODUCTS
(1) ALLEGRA (2) OKINAWA (3) HIAMA (4) GRISELDA (5) GARLAND LIFT
(6) LUCEO (7) REONA (8) WALLY (9) PLAY DISK

*Wally pot pag. 91

Glossary

White light (included) 	 Artificial plants included
Warm light (included) 	 Cherry bulb included
RGB light (included) 	 Solar panel
Led tube Lighting 	 String
Flame effect led light 	lm Lumens
Remote control 	 Packaging
Dimmable 	 Weight
Touch control 	 Solar + electric charge
Twilight sensor 	 Electric charge
Motion sensor 	 Solar charge
Hanging product 	 AAA bateries
Play music 	 Hardwire
Integrated speaker 	 Cable
Main Material 	 Jute Cable
Floating, not submersible 	 Magnetic
Floating & submersible 	 Connectable
Planter volume 	IP Indicates the level of protection of the electrical or electronic equipment against the entry of external agents: dust or water
Includes water reservoir 	

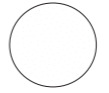
Polyethylene Textures

	SMOOTH TEXTURE Polyethylene		RUSTIC TEXTURE Polyethylene
---	---------------------------------------	---	---------------------------------------

Newgarden's products made of polyethylene have a visually smooth and softly granulated finish that is very pleasant to the touch.



The rustic finish can be found in a very specific selection of flowerpots.

Colours & Finishes

TRANSLUCENT POLYETHYLENE & ABS

	WHITE Polyethylene		LIME Polyethylene		RECYCLED BLUE Recycled fishing nets		RECYCLED MULTICOLOUR Recycled detergent bottles
---	------------------------------	---	-----------------------------	---	---	---	---

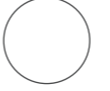
OPAQUE POLYETHYLENE

	WHITE Polyethylene		BLACK Polyethylene		BRONZE Polyethylene		TERRACOTTA Polyethylene		TAUPE Polyethylene		ANTHRACITE Polyethylene
--	------------------------------	--	------------------------------	--	-------------------------------	--	-----------------------------------	--	------------------------------	--	-----------------------------------

OTHER MATERIALS

	OPAQUE GLOSSY WHITE ABS		OPAQUE GLOSSY BLACK ABS		OPAQUE WHITE Metal		OPAQUE MINT Metal		OPAQUE BRASS Metal		OPAQUE ROSE GOLD Metal
	OPAQUE LIME Metal		OPAQUE WOOD EFFECT Metal		OPAQUE GREY ABS		OPAQUE SPACE GREY Metal		OPAQUE BEIGE ABS		OPAQUE ANTHRACITE Metal

	OPAQUE TAUPE GREY RECYCLED PVC
---	--

Certain products may feature a blend of various materials, and in such instances, we will identify and highlight the predominant material in the product.

(*) To ensure optimal maintenance, it is essential to shield these items from rain, direct sunlight, and abrupt temperature changes. Natural materials such as bamboo, rattan, beechwood, or seaweed may undergo color changes or develop cracks over time. When exposed to natural elements, it is advisable to regularly apply a suitable oil or varnish for each specific material. This not only extends protection against rain and UVA rays but also enhances the product's longevity. For cleaning, use a cloth or a brush to eliminate dust, and gently rub with a slightly moistened sponge.

Use according to IP.

Here you can find information about the possible uses of Newgarden's products according to their IP (index of protection of the electrical or electronic system against external agents)

IP20

Newgarden's products with IP20 can only be used indoors, the electrical system, switches or cables must be protected from direct contact with water. Note that, although the product is made of Polyethylene, which is resistant to external agents, the electrical system is designed for **indoor use only**.



IP43

Newgarden's products with IP 43 / 44 can be used outdoors, it is protected against dust and weak and very moderate rain. **If this product also have accessories made of natural fibres, wood or metal parts, it is advisable to protect it from direct contact with water and humidity.** Store it in a dry place after use.

IP44

In the event of rain or very adverse weather conditions, it should be protected from these external agents to avoid future problems.



IP54

Newgarden's products with IP 54 **can be used outdoors, as they are protected against dust and light rain.** If this product also has accessories made of natural fibres, wood or metal parts, it is advisable to protect it from direct contact with water and humidity. Store it in a dry place after use. In case of rain or very adverse weather conditions it must be protected from these external agents to avoid future problems.



IP65

Newgarden's products with IP 65 **can be used outdoors, they are airtight against dust and rain.** If this product also has accessories made of natural fibres, wood or metal parts, it is advisable to protect it from direct contact with water and humidity. Store it in a dry place after use. In case of rain or very adverse weather conditions it must be protected from these external agents to avoid future problems.



IP67

Newgarden products with IP67 are dust-tight and rainproof. They are also floating (submersion is not recommended) so they can be used in swimming pools. They must be protected against very adverse weather conditions.

IP68

Newgarden products with IP68 are dust-tight and rainproof. They are also floating and submersible (according to each product's own instructions for use) so they can be used in swimming pools. They must be protected against very adverse weather conditions.



The possible differences between the original color, illumination and color captured are due to the printing technique.

NEWGARDEN reserves the right over photographs and designs made, so it is forbidden the manufacture, distribution and / or marketing of the products shown on any media.

NEWGARDEN reserves the right to modify, in whole or in part, without prior notice, any information or technical specification of this publication.

All the information that appears in this catalog in terms of dimensions and capacity are approximate and are susceptible to variations due to improvements in the production process.

#BeHappy

@ Copyright. 2024. Newgarden Spain.

All rights reserved

**Avenida de Francia, 5-15 30840
Alhama de Murcia. Murcia (Spain)
info@newgarden.es
www.newgarden.es
T. +34 968978806**